

Construction Air Quality Management Plan
CHBPW-FGJV-NWW-AH-PLN-000001- Revision H - Coffs
Harbour Bypass

FERROVIAL GAMUDA JOINT VENTURE

THIS PAGE IS LEFT INTENTIONALLY BLANK

DOCUMENT DETAILS

Document Title	Construction Air Quality Management Sub-Plan
Project Name	Coffs Harbour Bypass
Client	Transport for New South Wales
Application No.	SSI-7666
Document Reference No.	CHBPW-FGJV-NWW-AH-PLN-000001
Principal Contractor	Ferrovial Gamuda Joint Venture

DOCUMENT AUTHORISATION

	Name	Position	Signature	Date
Prepared by	Reina Iligan	FGJV Environment Coordinator		
Reviewed by	Erran Woodward	FGJV Approvals Lead		
Approved by	Hari Corliss	FGJV Environment & Sustainability Manager		
Approved by	Daniel Perez	FGJV Project Director		
Approved by	Scott Lawrence	TfNSW Representative		
Endorsed by	Duncan Thomson	Environmental Representative		

VERSION CONTROL

Revision	Date	Description	Approval
A	July 2021	Draft for TfNSW, Agencies and ER review	
B	August 2021	Update following TfNSW, Agencies and ER review	
C	September 2021	Update following DPIE review	
D	August 2022	FGJV Draft for TfNSW and ER Review	
E	September 2022	FGJV Update following TfNSW Review	
F	October 2022	FGJV Update following ER Review	
G	November 2022	FGJV Update following ER Review	
H	November 2022	FGJV Update following DPE Review	

DISTRIBUTION OF CONTROLLED COPIES

This CEMP is available to all personnel and sub-contractors via the project document control management system. An electronic copy can be found on the project website.

The document is uncontrolled when printed. One controlled hard copy of the CEMP and supporting documentation will be maintained by the Quality Manager at the project office and on the project website.

Copy No.	Issued to	Version
1		
2		
3		
4		
5		

GLOSSARY/ABBREVIATIONS

Abbreviation	Expanded Text
CAQMP	Construction Air Quality Management Sub-Plan
BOM	Australian Government Bureau of Meteorology
CEMP	Construction Environmental Management Plan
DAWE	Department of Agriculture, Water and Environment
DDG	Dust Depositional Gauge
DPE	Department of Planning and Environment
DPE, EESG	Department of Planning and Environment – Environment, Energy and Science Group
EIS	Environmental Impact Statement
EP&A Act	Environmental Planning and Assessment Act 1979
EPBC Act	Environmental Protection and Biodiversity Conservation Act 1999
EPA	NSW Environment Protection Authority
EWMS	Environmental Work Method Statements
FGJV	Ferrovial Gamuda Joint Venture
GREP	Government Resource Efficiency Policy
MCoA	Minister’s Condition of Approval
NEPM	National Environment Protection Measures
TSP	Total Suspended Particulates
POEO Act	Protection of the Environment Operations Act 1997
REMMs	Revised Environmental Management Measures
TfNSW	Transport for NSW

CONTENTS

1	Introduction	7
1.1	Context	7
1.2	Background	7
1.2.1	Construction	7
1.3	Environmental Management Systems Overview	7
2	Purpose and Objectives	9
2.1	Purpose	9
2.2	Objectives	9
2.3	Targets	9
2.4	Environmental Performance Outcomes	9
3	Environmental Requirements	10
3.1	Relevant Legislation and Guidelines	10
3.1.1	Legislation	10
3.1.2	Guidelines	10
3.2	Minister’s Conditions Of Approval	11
3.3	Environmental Management Measures	12
3.4	Environment Protection Licence	13
4	Existing Environment	14
4.1	Sensitive Receivers	14
4.2	Local Meteorology	15
5	Environmental Aspects and Impacts	16
5.1	Construction Aspects	16
5.2	Factors Affecting Dust Generation	17
5.3	Potential Air Quality Impacts	17
6	Environmental Mitigation and Management Measures	19
7	Compliance Management	23
7.1	Roles and Responsibilities	23
7.2	Training	23
7.3	Complaints Management	23
7.4	Monitoring	23
7.4.1	Meteorological Monitoring	23
7.4.2	Air Quality Monitoring Program	24
7.5	Ongoing Air Quality Risk Analysis	24
7.6	Auditing	24
7.7	Reporting	24
8	Review and Improvement	25
8.1	Continuous Improvement	25
8.2	Update and Amendment	25
Appendices 26		
Appendix A Construction Air Quality Monitoring Program		27

TABLES

Table 1 Principal legislation and Regulation relevant to Air Quality	10
Table 2 Conditions of Approval relevant to the CAQMP	11
Table 3 Environmental Management Measures Relevant to this CHMP	12
Table 4 Sensitive human and ecological receivers relevant to the Project	14
Table 5 Air Quality Management and Mitigation Measures	19

1 INTRODUCTION

1.1 CONTEXT

This Construction Air Quality Management Sub Plan (CAQMP or Plan) forms part of the Construction Environmental Management Plan (CEMP) for the Coffs Harbour Bypass (the Project or CHB).

This CAQMP has been prepared to provide a framework to facilitate effective management of air quality during construction in accordance with the requirements of the Minister's Conditions of Approval (MCoA), the Revised Environmental Management Measures (REMMs) listed in the Coffs Harbour Bypass Environmental Impact Statement (EIS) and all applicable legislation.

1.2 BACKGROUND

The Coffs Harbour Bypass EIS (Chapter 21) considered the potential air quality impacts during the construction of the project. The background of the project is described in Section 1 of the CEMP.

The Project includes the construction of a 14-kilometre bypass of Coffs Harbour, including a 12-kilometre new build from south of Englands Road to Korora Hill in the north and a two-kilometre upgrade of the existing highway between Korora Hill and Sapphire. The Project would provide a four-lane divided highway that bypasses Coffs Harbour, passing through the North Boambee Valley, Roberts Hill and then traversing the foothills of the Coffs Harbour basin to the west and north to Korora Hill.

1.2.1 CONSTRUCTION

During construction, the main potential air quality impacts are primarily due to dust generation and exhaust emissions from diesel powered construction equipment. Impacts are likely to be higher where there are higher numbers of sensitive receptors, such as the southern and northern tie-ins of the project where residential receptors, community facilities and food handling facilities are located along existing roads. Construction vehicle exhaust emissions have the potential to impact on local air quality. Provided the construction vehicles are well maintained, the volume and impact of exhaust emissions during construction is expected to be substantially lower than that from vehicle emissions on existing roads.

During the construction phase, there is potential for some short-term odour impacts from asphalt laying, batching plants, blasting and earthworks stabilisation. This would potentially impact receivers in very close proximity to these works and the level of impact would be dependent on meteorological conditions at the time. Any impact would be temporary, localised and short term while the activity is being carried out.

Overall, construction dust is unlikely to present a serious ongoing problem provided that effective management, mitigation and monitoring measures are in place. As described above, any effects would be temporary and relatively short-lived, and subject to at-source mitigation measures and proactive management measures to reduce impacts to sensitive receivers.

1.3 ENVIRONMENTAL MANAGEMENT SYSTEMS OVERVIEW

The CEMP describes the overall system for environmental management and that system forms part of the environmental management framework of the Coffs Harbour Bypass project. The environmental management system overview is described in Section 4 of the CEMP.

The CAQMP has been developed as part of the CEMP in consultation with:

- NSW Department of Planning and Environment
- Coffs Harbour City Council
- EPA NSW
- DPI Agriculture.

The relevant CAQMP environmental control measures will be incorporated in detailed location or activity-specific Environmental Work Method Statements (EWMS) prepared and implemented for all [FERROVIAL GAMUDA JOINT VENTURE](#)

high-risk construction activities that have the potential to impact local air quality. The EWMS will detail measures to avoid impacts to local air quality during construction activities. EWMS will be developed in accordance with Section 4.1.5 of the CEMP.

The review and document control processes for this Plan are described in Section 8 of the CAQMP and further detail included in Section 9 of CEMP.

2 PURPOSE AND OBJECTIVES

2.1 PURPOSE

The purpose of this Plan is to describe how air quality impacts will be managed to reduce potential impacts to sensitive receivers during construction of the Project.

2.2 OBJECTIVES

The key objectives of the CAQMP are to ensure all project approval requirements, environmental management measures and licence requirements relevant to air quality are described, scheduled and assigned responsibility as outlined in:

- The Environmental Impact Statement, Submissions and Amendment Reports prepared for the CHB project
- Ministers Conditions of Approval
- Transport for NSW (TfNSW) Specifications G36, G38 and G40
- NSW EPA issued Environment Protection Licence.

To achieve compliance with the conditions and objectives of the Project documents above, the Ferrovial Gamuda Joint Venture (FGJV) will undertake the following:

- Ensure measures (Table 5, Section 6 of this AQMP) are implemented to address the relevant MCoA outlined in Table 1 and the safeguards detailed in the Submissions Report REMMs in Table 2.
- Ensure best management practice controls and procedures are documented, communicated and implemented during construction activities to avoid or minimise air quality impacts to sensitive receivers along the project corridor.

2.3 TARGETS

The following targets have been established for the management of air quality impacts during the project:

- Ensure full compliance with the relevant legislative requirements, MCoA and environmental management measures monitoring
- Ensure training on best practice air quality management is provided to all construction personnel through project and site-specific inductions.

2.4 ENVIRONMENTAL PERFORMANCE OUTCOMES

The EIS outlined a set of performance outcomes in Section 29-4. The performance outcome related to construction air quality is:

Dust, odour and other emissions during construction are effectively managed through the implementation of the Air Quality Management Plan.

This CAQMP is a response to the above EIS construction air quality performance outcome.

3 ENVIRONMENTAL REQUIREMENTS

This section describes the legislative, regulatory and guidance framework that applies to the Project.

3.1 RELEVANT LEGISLATION AND GUIDELINES

3.1.1 LEGISLATION

Table 1 lists the principal legislation and regulation that applies to air quality management.

TABLE 1 PRINCIPAL LEGISLATION AND REGULATION RELEVANT TO AIR QUALITY

Legislation and Regulation	Relevance
Commonwealth	
<i>Environment Protection Biodiversity Conservation Act, 1999 (EPBC Act) (Commonwealth)</i>	Provides for the protection of matters of national environmental significance including species, populations, communities and their habitat that could be impacted by contamination or pollution
<i>Environment Protection and Biodiversity Conservation Regulation 2000 (as amended).</i>	Provides for the protection of world heritage sites (including the Gondwana Rainforests) and wetlands of international importance (i.e. Ramsar sites).
<i>National Environmental Protection Council Act 1994</i>	Establishes the National Environmental Protection Council (NEPC) and the concept of National Environmental Protection Measures (NEPMs)
<i>National Greenhouse and Energy Reporting Act 2007</i>	Provides the statutory basis for the National Greenhouse and Energy Reporting Scheme in relation to greenhouse gas emissions and energy consumption and production.
State	
<i>Environmental Planning and Assessment Act 1979 (EP&A Act).</i>	Describes the processes for consenting development in NSW, managing land use and implementing environmental planning instruments. Also describes certain permitting and licencing streaming and exclusion provisions that will apply to the project
<i>Protection of the Environment Operations Act 1997 (POEO Act)</i>	Pollution control, incident notification and the provision of Environment Protection Licences.
<i>Protection of the Environment (Clean Air) Regulation 2002 (as amended)</i>	Key regulatory mechanism for reducing air emissions.
<i>Protection of the Environment (Ambient Air Quality) Regulation 1998 (as amended)</i>	Framework for protecting environmental and human health
<i>Protection of the Environment Operations (Clean Air) Regulation 2010</i>	Provides regulatory measures to control emissions from wood heaters, open burning, motor vehicles and fuels and industry.

3.1.2 GUIDELINES

The main guidelines, specifications and policy documents relevant to this plan include:

- Protection of the Environment Operations (Clean Air) Regulation 2010
- Approved Methods for the Modelling and Assessment of Air Quality Pollutants in NSW (EPA 2017a)
- National Environment Protection Councils (NEPC) – National Environment Protection Measure (NEPM) for Ambient Air Quality Guidelines (Australian Government 2016)
- Local Government Air Quality Toolkit (EPA 2017c)
- The Control of dust and emissions during construction and demolition supplementary planning guidance (GLA 2014)

- AS 3580.1.1-2007 Methods of Sampling Analysis of Ambient Air. Part 1.1 Guide to Siting Air Monitoring Equipment
- AS 3580.10.1-2003 Methods of Sampling Analysis of Ambient Air. Determination of Particulate Matter – Deposited Matter – Gravimetric Method
- Managing Urban Stormwater: Soils and Construction, Volume 1 (Landcom 2004) and Volume 2 (DECC 2008) (the “Blue Book”)
- TfNSW QA Specification G36 – Environmental Protection (Management System)
- TfNSW QA Specification G38 – Soil and Water Management
- CHB Panama Disease Control Management Plan.

3.2 MINISTER’S CONDITIONS OF APPROVAL

The MCoA relevant to this Plan are listed in Table 2 below. A cross reference is also included to indicate where the condition is addressed in this Plan or other Project management documents.

TABLE 2 CONDITIONS OF APPROVAL RELEVANT TO THE CAQMP

CoA No.	Condition Requirements	Document Reference	
C4	The CEMP Sub-plans in Table 3 must be prepared in consultation with the government agencies identified for each CEMP Sub-plan. The outcomes of consultation with government agencies in accordance with Condition A5 must be provided with the relevant CEMP Sub-Plan.	Consultation records to be provided to DPE with CEMP and Sub-Plan submissions	
	(a)		Air quality
C5	The CEMP Sub-plans must state how:	(a) Section 2	
	(a) the environmental performance outcomes identified in the documents listed in Condition A1 will be achieved;	(b) Section 6	
	(b) the mitigation measures identified in the documents listed in Condition A1 will be implemented;	(c) Section 3	
	(c) the relevant terms of this approval will be complied with; and	(d) Section 4, 5, 6, 7, 8.	
C6	(d) issues requiring management during construction, as identified through ongoing environmental risk analysis, will be managed.		
	Any of the CEMP Sub-plans may be submitted along with, or subsequent to, the submission of the CEMP but in any event, no later than one (1) month before construction.	Noted	
C12	Construction must not commence until the CEMP and all CEMP Sub-plans have been approved by the Planning Secretary. The CEMP and CEMP Sub-plans, as approved by the Planning Secretary, including any minor amendments approved by the ER must be implemented for the duration of construction. Where construction of the CSSI is staged, construction of a stage must not commence until the CEMP and sub-plans for that stage have been approved by the Planning Secretary.	Document control and approvals detailed in CAQMP version control table	
C13	The Construction Monitoring Programs in Table 4 must be prepared in consultation with the relevant government agencies identified for each to compare actual performance of construction of the CSSI against the performance predicted in documents listed in Condition A1 or in the CEMP.	Air Quality Monitoring Program included in Appendix A of the CAQMP	
	(a)		Air quality

CoA No.	Condition Requirements	Document Reference
E1	In addition to the performance outcomes, commitments and mitigation measures specified in the documents listed in Condition A1, all reasonably practicable measures must be implemented to minimise the emission of dust and other air pollutants during the construction and operation of the CSSI.	Section 6

3.3 ENVIRONMENTAL MANAGEMENT MEASURES

Relevant EMMs are listed in Table 3 below. This includes references to required outcomes, the timing of when the commitment applies, relevant documents or sections of the environmental assessment influencing the outcome and implementation.

TABLE 3 ENVIRONMENTAL MANAGEMENT MEASURES RELEVANT TO THIS CHMP

Outcome	Ref#	Commitment	Timing	CAQMP Reference
Management of construction impacts	AQ01	An Air Quality Management Plan will be prepared and implemented as part of the CEMP. The plan will identify:	Prior to and during construction	Section 5
		<ul style="list-style-type: none"> Potential sources of air pollution (such as dust, vehicles transporting waste, plant and equipment) during construction 		Section 4.1
		<ul style="list-style-type: none"> Identification of all dust sensitive receivers, including banana and blueberry farms, residential dwellings, education institutions, health care facilities, places of worship, childcare facilities and open space 		Sections 3, 5, 6 and Appendix A
		<ul style="list-style-type: none"> Air quality management objectives and criteria consistent with Approved Methods for the Modelling and Assessment of Air Quality Pollutants in NSW (EPA 2017a) 		Section 6 – AQMM04, AQMM07, AQMM13, AQMM14, AQMM15, AQMM20
		<ul style="list-style-type: none"> Mitigation and suppression measures to be implemented, such as using soil binders or covering exposed surfaces, provision of vehicle clean down areas, covering of loads, use of water carts and street cleaning, use of dust screens, maintenance of plant in accordance with manufacturer's instructions, spray bars on crushers 		Section 6 – AQMM19, AQMM24
		<ul style="list-style-type: none"> Methods to manage or stop works during strong winds or other adverse weather conditions 		Section 6 – AQMM04, AQMM05
		<ul style="list-style-type: none"> A progressive rehabilitation strategy for exposed surfaces 		Section 6
		<ul style="list-style-type: none"> When the air quality, suppression and management measures need to be applied and who is responsible 		Appendix A
		<ul style="list-style-type: none"> A monitoring program to assess the effectiveness of the applied measures in accordance with Approved Methods for Sampling and Analysis of Air Pollutants in NSW (Department of Environment and Conservation NSW 2007) 		Section 7.3
		<ul style="list-style-type: none"> Community notification and complaint handling Procedures 		

Outcome	Ref#	Commitment	Timing	CAQMP Reference
Dust generation from building demolition	AQ02	Where buildings and structures are required to be demolished, techniques and practices will be developed to minimise dust generation such as water spraying during demolition as required, and the removal of construction debris along an approved route documented in the Air Quality Management Plan.	During construction	Section 5 and 6 – AQMM02
Construction vehicle emissions	AQ03	Where practicable, construction vehicles will be fitted with pollution reduction devices and switched off when not in use.	During construction	Section 6 – AQMM14
Odour impacts from asphalt batch plants	AQ04	Asphalt batch plants established for the project will include the following measures to minimise odour generation: <ul style="list-style-type: none"> • Bitumen products will be maintained at the minimum temperature possible to minimise odorous emissions • Particulate extraction equipment will be installed, operated and maintained for efficiency in minimising odour impacts • Filters and burners will be adequately maintained to minimise odour impacts • Commission testing will be carried out prior to full operation to ensure that best practice industry standards are met during the operation of the batch plant • An assessment of prevailing winds and the location and direction of receivers when selecting an appropriate asphalt batch plant site. 	During construction	Section 6 – AQMM16
Dust impacts - Agriculture	AG06	Real time dust monitoring will be carried out at representative locations of dust sensitive agricultural receivers along the project alignment to allow for the timely management of dust generation on-site and to minimise potential impacts. The representative locations of dust sensitive agricultural receivers will be determined during detailed design and will include the Oz Group Packhouse. Monitoring will be carried out in accordance with the Approved Methods for the sampling and analysis for air pollutants in NSW (EPA 2017a) where applicable.	Prior to and during construction	Section 7.4
Wind and microclimate impacts	AG07	An Automatic Weather Station will be established at a representative location to confirm the outcomes of the wind flow and microclimate investigations. The Automatic Weather Station will be established in accordance with the Bureau of Meteorology's Observation Specification No. 2013.1: Guidelines for siting and exposure of meteorological instruments and observing facilities.	Prior to, during and post construction	Section 6 – AQMM22 Section 7

3.4 ENVIRONMENT PROTECTION LICENCE

An Environment Protection Licence (EPL) will be sought for the Project. Upon award, this Plan will be updated to reflect any licence requirements or conditions applicable to air quality.

4 EXISTING ENVIRONMENT

The following sections summarise what is known about factors influencing air quality impacts and management associated with the Project, within and adjacent to the project corridor.

The key reference document is Chapter 21 of the EIS.

Local air quality in Coffs Harbour CBD is dominated by emissions from transport, which is common for most urban areas around Australia. The air quality of the surrounding area is likely to be dominated by a mix of agricultural activity and transport emissions.

4.1 SENSITIVE RECEIVERS

The EIS defined two categories of sensitive air quality receivers as being potentially impacted by construction activities associated with the project:

- Ecological receivers – defined as natural environments such as the Kororo Nature Reserve and agricultural land uses (focussed on Blueberry and Banana growers)
- Sensitive human receivers – a range of sensitive (human) receptors including schools and residences identified within the study area

Sensitive human and ecological receivers relevant to the Project have been detailed in Table 4.

TABLE 4 SENSITIVE HUMAN AND ECOLOGICAL RECEIVERS RELEVANT TO THE PROJECT

Category	Sensitive receivers relevant to the Project
Educational Institutions	<ul style="list-style-type: none"> • Kororo Public School • Bishop Druitt College • Boambee Public School • Coffs Harbour Montessori Preschool
Healthcare Facilities	<ul style="list-style-type: none"> • Coffs Harbour Health Campus • Coffs Harbour GP Super Clinic
Places of Worship	<ul style="list-style-type: none"> • The Foursquare Church Australia
Childcare Facilities	<ul style="list-style-type: none"> • Petit Early Learning Centre Coffs Harbour • Cow & Koala Professional Child Care
Areas of open space (active use)	<ul style="list-style-type: none"> • Coffs Coast Sport and Leisure Park • Pacific Bay Resort Golf Course • Elite Training Centre Pacific Bay Resort • Boambee Equestrian Centre
Agricultural land uses	<ul style="list-style-type: none"> • Primarily banana and blueberry cultivation, (noting that that blueberry fruit has potential to spoil when exposed to excessive dust) • Oz Group berry packaging and processing facility located near the England's Road Interchange • The sensitivity of beehives used for honey production to airborne dust has been raised during consultation with project stakeholders, currently no properties have been identified adjacent to the project corridor with bee keeping activities being undertaken.
Retained Threatened Flora Species (exclusion zone)	<ul style="list-style-type: none"> • Exclusion zone located adjacent to the mainline construction footprint in proximity to Jordans Creek • Pittosporum sp. • Fontaine sp.

Other receivers identified include various large-scale retail shops, businesses and light industrial receivers. Most of these are located at the Isles Drive Mixed Use Centre, just north of England's Road interchange at the southern end of the project. The EIS assessed the type and location of sensitive receivers within 350 metres of the boundaries of the project alignment, mapping of sensitive receivers

and monitoring locations is included in the Air Quality Monitoring Program in Appendix A, in addition to further information on baseline monitoring outcomes and ambient air quality conditions.

4.2 LOCAL METEOROLOGY

Local meteorology influences dispersion and air quality conditions in an area. Local meteorological data for the area is available from the Bureau of Meteorology (BoM) weather station at Coffs Harbour Airport. Wind data available from this station for recent years (2015–2017) shows that the most common wind directions are from the south-west and the north. North-easterlies are more common in spring and summer, while south-westerlies and north-westerlies are most common in autumn and winter. The average wind speeds from 2011 to 2017 for this location are consistent and relatively high (varying from 4.1 m/s to 4.4 m/s). This suggests that any pollution is likely to be well dispersed in the area.

5 ENVIRONMENTAL ASPECTS AND IMPACTS

5.1 CONSTRUCTION ASPECTS

Emissions to the atmosphere during construction that could result in adverse impacts to air quality are typically divided into two categories. These are:

- Dust and particulates
- Gaseous.

Key aspects of the project that could result in dust emissions include:

- General earthworks particularly during site establishment
- Vegetation clearing
- Bulk Earthworks
- Drilling and Blasting
- Operating crushing and screening equipment
- Operation of concrete / asphalt batching plants
- Topsoil / material handling including stockpiling, material loading and material haulage
- Vehicular movements over unpaved surface (including unsealed access roads)
- Wind erosion of exposed areas and temporary stockpiles
- Tracking of dirt onto roads.

Air emissions, other than dust, which may be generated by construction activities include:

- Vehicle and plant exhaust emissions, which may be excessive if vehicles and plant are poorly maintained
- Odours/gases released during:
 - Excavations of organic or contaminated materials
 - During sealing works
 - Operation of concrete / asphalt batching plants.

Chapter 21.6 of the CHB EIS provides an assessment of the potential air quality impacts related to the construction phase of the project, which has been used as a framework for construction air quality monitoring. Findings of the assessment are summarised below:

Particulates and emissions

During construction, the main air quality impacts would be primarily due to dust generation (including elevated PM₁₀ TSP concentrations due to dust generating activities), and exhaust emissions from diesel- powered construction equipment.

The potential for exposure to dust emissions can depend on the type of construction work, duration and frequency of the activity in any given locality, the prevailing wind speed and direction and the relative location of nearby sensitive receivers.

There is potential for adverse dust impacts at sensitive receivers surrounding the construction footprint as winds could be capable of transporting emissions. Adverse impacts from high dust levels include health effects (from smaller particles) and soiling and amenity impacts (due to fallout of the larger particles). The impacts are generally greater during dry weather periods and high wind conditions.

For all construction activity, the aim would be to prevent significant impacts on sensitive receivers, through the implementation and use of effective mitigation measures. Given the proximity and number of sensitive receivers to the construction footprint, there is the risk that they would experience some occasional dust spoiling impacts. However, it is anticipated that impacts would be local and temporary.

Primary activities which would generate dust from the construction would include:

- Clearing of vegetation and topsoil
- Excavation and levelling of soil
- Earthworks for cut and fill areas
- Movement of soil and fill by dump trucks and scrapers

- Wind erosion from unsealed surfaces and stockpiles
- Wheel-induced dust from construction vehicles travelling on unsealed areas
- Rock crushing and screening
- Concrete and asphalt batching.

Impacts are likely to be higher where there are higher numbers of sensitive receptors, such as the southern and northern tie-ins of the project where residential receptors, community facilities and food handling facilities/restaurants are located along existing roads. There are also a number of ecological receptors located throughout the study area, predominantly agricultural properties (such as banana and blueberry plantations). Dust impacts can lead to discolouration and soiling of crops, as well as potentially inhibiting plant growth. The susceptibility of dust impacts on blueberry and banana farms is discussed further in Chapter 13 of the EIS, Agriculture.

Construction vehicle exhaust emissions have the potential to impact on local air quality. Vehicle exhaust emissions depend on the fuel type, fuel quality, power output and operating condition of the engine. All construction vehicles (including light vehicles) are expected to be maintained in a serviceable condition. Providing the construction vehicles are well maintained, the volume and impact of exhaust emissions during construction is expected to be substantially lower than that from vehicle emissions on existing roads.

Odour

During the construction phase, there is potential for some short-term odour impacts from asphalt laying, batching plants, blasting and earthworks stabilisation. This would potentially impact receivers in very close proximity to these works and the level of impact would be dependent on meteorological conditions at the time. Any impact would be temporary, localised and short term while the activity was being carried out. A detailed assessment of proposed potential asphalt batching sites will be prepared in accordance with the approval and assessment procedures detailed in the Construction Ancillary Sites Establishment Management Plan, incorporating odour impact assessments to minimise any amenity or health concerns. Best practice management measures also would be incorporated into the establishment and operation of the asphalt batching plants to avoid or minimise potential odour impacts.

5.2 FACTORS AFFECTING DUST GENERATION

In addition to the inherent risks of specific construction activities creating the potential to generate dust, a number of other environment factors also affect the likelihood of dust emissions. These include:

- Wind direction – determines whether dust and suspended particles are transported in the direction of the sensitive receivers
- Wind speed – governs the potential suspension and drift resistance of particles
- Soil type – more erodible soil types have an increased soil or dust erosion potential
- Soil moisture – increased soil moisture reduces soil or dust erosion potential
- Groundcover – increased disturbed areas associated with construction can lead to increased dust generation and erosion
- Rainfall or dew – rainfall or heavy dew that wets the surface of the soil and reduces the risk of dust generation.

5.3 POTENTIAL AIR QUALITY IMPACTS

The potential for impacts on air quality will depend on a number of factors. Primarily, impacts will be dependent on the nature, extent and magnitude of construction activities and their interaction with the natural environment. Potential impacts attributable to construction might include:

- Potential adverse health effects including eye, nose and throat irritation from excessive inhalation of fine particles
- Impacts on agricultural production, in particular blueberries which are sensitive to dust spoiling prior to picking and the risk of potential spread of Panama Disease to susceptible banana cultivation areas
- Impacts on water quality and/or vegetation health from dust deposition

- Deposition of dust on surfaces where it may cause damage and/or lead to a need for increased cleaning or repair
- Aesthetic effects that arise from visible airborne dust plumes and from deposits of dust on surfaces
- Need for increased maintenance of air filtering systems (e.g. air conditioners etc.)
- Impacts on residential sensitive receivers, including impacts on living areas, swimming pools and general amenities
- Amenity impacts resulting in complaints from the public relating to dust or odours.

Some impacts on air quality attributable to the project are anticipated and have been described in the EIS. Section 6 provides a suite of mitigation measures that will be implemented to avoid or minimise those impacts.

6 ENVIRONMENTAL MITIGATION AND MANAGEMENT MEASURES

Specific measures and requirements to meet the objectives of this CAQMP and to address impacts on air quality are outlined in Table 5.

TABLE 5 AIR QUALITY MANAGEMENT AND MITIGATION MEASURES

ID	Measure/Requirement	When to implement	Responsibility	Source
AQMM01	Air quality control measures from this plan will be included in relevant Environmental Work Method Statements (EWMS) and/or Erosion and Sediment Control Plans (ESCP).	During construction	Environmental Manager	TfNSW Specifications
AQMM02	<p>Where buildings and structures are required to be demolished, techniques and practices will be developed to minimise dust generation such as water spraying during demolition as required. Hazardous Material Assessments are to be completed prior to commencement of demolition activities and all works to be carried out in accordance with Safe Work NSW requirements.</p> <p>Where required, debris (rock, soil, timber, construction materials) associated with the construction of the Project would be removed from approved construction access routes. Construction access routes are detailed in the Construction Traffic and Transport Management Plan.</p> <p>Removal of debris would include but not be limited to the use of a street sweeper and manual labour as required.</p>	During construction	Foreman Construction Manager Environmental Manager	REMM AQ02 Construction Traffic and Transport Management Plan.
AQMM03	Vegetation clearing will be staged where possible to minimise the area and time that surfaces are exposed.	During construction	Foreman Environmental Manager	TfNSW Specification G40
AQMM04	<p>Exposed surfaces with no scheduled work for two weeks will be treated to minimise dust generation.</p> <p>Exposed surfaces will be stabilised progressively using the most practical site specific methods, such as watering for short term exposure and emulsion spray, soil binder, spray grass, soil compaction and revegetation for longer term exposed areas or final finishes.</p>	During construction	Foreman	REMM AQ01
AQMM05	<p>Stockpiles will be located in accordance with the criteria established in The Stockpile Management Protocol included in the CSWMP.</p> <p>Control measures including water carts, sprinklers, sprays, dust screens or the application of geo-binding agents will be utilised where applicable to control dust emissions.</p> <p>In circumstance where stockpiles may contain contaminated soil, management</p>	During construction	Foreman	CSWMP

ID	Measure/Requirement	When to implement	Responsibility	Source
	<p>practices are to be implemented in accordance with the Site Contamination Report or site specific Hazardous Materials Assessment requirements.</p> <p>Management of asbestos and asbestos containing material will be in accordance with the Project Asbestos Management Plan.</p>			
AQMM06	Temporary stockpiles that are planned to be in undisturbed for periods of over four weeks will be temporarily seeded and stabilised. A suitable cover crop or provision of other covering over topsoil stockpiles will be established where stockpiles are in place for longer than four weeks.	During construction	Foreman	CSWMP
AQMM07	The application of pesticides and herbicides will be modified, reduced or controlled during high or unfavourable wind conditions where wind can carry pesticides outside of the defined treatment area.	During construction	Foreman Environmental Manager	TfNSW Specification G36
AQMM08	Stormwater, recycled water or other water sources shall be used, where feasible and reasonable, in preference to potable water for construction activities, including concrete batching and dust control.	During construction	Foreman Environmental Manager	TfNSW Specification G38, Good practice
AQMM09	<p>Areas of disturbed material and access roads will be stabilised where possible by methods such as compaction.</p> <p>Compounds, ancillary facilities, access roads and parking areas will be sealed or constructed in a manner to mitigate dust generation</p>	During construction	Foreman	Good practice
AQMM10	<p>Measures implemented to minimise dust, soil or mud from being deposited from vehicles on public roads. This will be achieved by implementing mitigation measures such as rumble grids and large aggregate at entry/exit points.</p> <p>Manual cleaning will also be carried out where appropriate. In the event of any spillage or tracking, the spilt material will be removed as a priority.</p> <p>Management measures should include:</p> <ul style="list-style-type: none"> Watering of unsealed haul roads, as required Provision of vehicle wash down areas and facilities during periods of inclement weather, or as otherwise required. 	During construction	Project Engineer Foreman	Good practice, REMM AQ01
AQMM11	Hardstand areas and surrounding public roads will be cleaned, as required, using methods including brooms bobcat attachments or street sweepers.	During construction	Foreman	Good practice
AQMM12	Vehicle movement will be confined to designated haul roads and areas. These roads will have speed limits in place to	During construction	Foreman Traffic Manager	Good practice

ID	Measure/Requirement	When to implement	Responsibility	Source
	reduce dust generation. Reduced speed limit maybe implemented where dust generation persists.		Environmental Manager	
AQMM13	All loaded road haulage trucks will be covered where there is a risk of release of dust or other materials.	During construction	Truck drivers	Good practice
AQMM14	Where practicable, construction vehicles will be fitted with pollution reduction devices and switched off when not in use.	During construction	Procurement Manager Foreman	REMM AQ03
AQMM15	Exhaust systems of construction plant, vehicles and machinery will be maintained in accordance with manufacturer's specifications to ensure that emissions do not exceed EPA regulations.	During construction	Project Engineer	Good practice
AQMM16	Asphalt batch plants established for the project will include the following measures to minimise odour generation: <ul style="list-style-type: none"> • Bitumen products will be maintained at the minimum temperature possible to minimise odorous emissions • Particulate extraction equipment will be installed, operated and maintained for efficiency in minimising odour impacts • Filters and burners will be adequately maintained to minimise odour impacts • Commission testing will be carried out prior to full operation to ensure that best practice industry standards are met during the operation of the batch plant. • An assessment of prevailing winds and the location and direction of receivers when selecting an appropriate asphalt batch plant site. 	Construction	Project Engineer Construction Manager	REMM AQ04
AQMM17	High dust emitting structures or processors in batch plants (e.g. conveyer belts) will have water spraying systems installed to suppress dust.	Construction	Project Engineer Construction Manager	Good practice
AQMM18	Concrete batch plants to be fitted with dust filters or similar to minimise air quality impacts from batching operations.	Construction	Project Engineer Construction Manager	Good practice
AQMM19	Where practical during blasting, a combination of the following mitigation measures will be used to suppress dust: <ul style="list-style-type: none"> • Weather reports checked prior to blasting minimise the potential for windblown dust reaching surrounding residents. • Controlled blasts to minimise dust produced. 	Construction	Foreman Project Engineer	Good practice
AQMM20	Crushers will be positioned in protected areas, where practical, to reduce wind dispersion of dust particles (e.g. within cuts). Water spraying will be utilised if necessary.	Construction	Foreman Project Engineer	Good practice

ID	Measure/Requirement	When to implement	Responsibility	Source
AQMM21	An air quality monitoring program will be implemented to assess the effectiveness of the applied measures in accordance with Approved Methods for Sampling and Analysis of Air Pollutants in NSW (Department of Environment and Conservation NSW 2007)	Prior to and during construction	Environmental Manager	REMM AQ01
AQMM22	Automated weather stations are to be established at representative locations within the project alignment prior to construction. Rainfall, temperature and wind speed and direction are to be monitored.	Prior to and during construction	Environmental Manager	TfNSW Specification G36
AQMM23	Public roads will be inspected at least daily at main entry and exit points to and from areas where construction activities are taking place including the project compound and site offices. Material tracked onto the road pavement will be removed.	Construction	Foreman	Good practice
AQMM24	Weather forecast will be reviewed on a daily basis and appropriate measures implemented where unfavourable weather conditions (dry weather, wind speed >10m/s) are anticipated. This will include modifying or stopping works where mitigation measures are not adequate, and implementation of additional mitigation measures such as dust suppression with water carts, sprinklers and sprays, reduction in vehicle speeds, and application of soil binders.	Construction	Foreman Project Engineer	Good practice
AQMM25	Dust control and operational procedures will be reviewed and modified if results exceed the air quality criteria and are attributable to construction activities.	Construction	Project Engineer Environmental Manager	Good practice
AQMM26	Community complaints received in relation to air quality are to be managed in accordance with the Community Communication Strategy, all complaints are to be referred to the Community Team via the 1800 number (1800 550 621)	Prior to and during construction	Community Manager	REMM AQ01, Good practice

7 COMPLIANCE MANAGEMENT

7.1 ROLES AND RESPONSIBILITIES

The project team's organisational structure and overall roles and responsibilities are outlined in Section 4.2 of the CEMP. Specific responsibilities for the implementation of environmental controls are detailed in Section 6 of this Plan.

7.2 TRAINING

All employees, subcontractors and utility staff working on site will undergo site induction training relating to soil and water management issues. Training will address elements related to air quality management which may include:

- Existence and requirements of this sub-plan
- Relevant MCoA and legislation
- EPL conditions (e.g. specifically dust management competency and maintenance of plant and equipment conditions)
- Roles and responsibilities for air quality management
- Air quality mitigation and management measures
- Procedure to be implemented in the event of an incident (e.g. release of dust or gaseous emissions from site).

Targeted training in the form of toolbox talks or specific training will also be provided to personnel with a key role in air quality management.

Further details regarding staff induction and training are outlined in Section 5 of the CEMP.

7.3 COMPLAINTS MANAGEMENT

Community enquiries and complaints will be managed via the Community Complaints Management System as detailed in with the approved Community Communications Strategy.

Additionally, the environmental team will complete an inspection/review real time monitoring in response to community complaints associated with air quality.

7.4 MONITORING

7.4.1 METEOROLOGICAL MONITORING

Five automated weather stations have been installed across the project alignment. These stations provide the project with web-based access to real time weather conditions and records of rainfall, temperature, wind speed and direction and other meteorological parameters.

The weather stations are spaced evenly across the Project and are located at the following design chainages:

- CH10770
- CH11810
- CH14930
- CH18850
- CH23050.

The automated weather stations are sited in locations that are consistent with the Bureau of Meteorology's Observation Specification No. 2013.1: Guidelines for siting and exposure of meteorological instruments and observing facilities.

7.4.2 AIR QUALITY MONITORING PROGRAM

In accordance with MCoA C13-C19, the Construction Air Quality Monitoring Program has been prepared and developed in consultation with the relevant government agencies (Table 4). Refer to Appendix A.

Air quality will be monitored for the duration of the construction period of the project to provide verification of the effectiveness of mitigation and management measures implemented to minimise air quality issues.

7.5 ONGOING AIR QUALITY RISK ANALYSIS

Ongoing review and assessment of construction activities with potential to generate air quality impacts to sensitive receivers will be undertaken by the Project Team in the planning of construction activities with potential to generate air quality impacts from dust or odour. The FGJV Project team are required to ensure that the specific management and mitigation measures are implemented appropriately, and the required actions are to be included in the EWMS prepared prior to commencement of works in accordance with requirements detailed in the CEMP Section 4.1.5 and the details below. The EWMS are to include the following measures that are relevant to air quality:

- Identification of reasonable and feasible mitigation measures to be implemented, in accordance with the management and mitigation measures detailed Section 6 of this Plan
- Provision for visual monitoring of air quality impacts as part of works surveillance by site supervisors and environment staff, in the case of dust generating activities
- Review of monitoring results from real time air quality monitors and dispositional dust gauges against assessment criteria to assess compliance
- A trigger for further investigation into additional potential mitigation and management actions where monitoring indicates exceedances and /or where community complaints are received in relation to construction activities. Work method statements are to be updated accordingly to reflect altered practices and additional management and mitigation measures as required.

The management review procedures described in Section 9 of the CEMP which forms part of the ongoing project environmental risk review process is to include air quality management issues to ensure that best practice outcomes are achieved, and to incorporate lessons learnt in the planning process for ongoing works.

7.6 AUDITING

Audits (both internal and external) will be undertaken to assess the effectiveness of environmental controls, compliance with this sub plan, MCoA and other relevant approvals, licences and guidelines.

Audit requirements are detailed in Section 8.3 of the CEMP.

7.7 REPORTING

Reporting requirements related to air quality monitoring are detailed in the Air Quality Monitoring Program (Appendix A).

All other reporting requirements and responsibilities are documented in Section 8 of the CEMP.

8 REVIEW AND IMPROVEMENT

8.1 CONTINUOUS IMPROVEMENT

Continuous improvement of this Plan will be achieved by the ongoing evaluation of environmental management performance against environmental policies, objectives and targets for the purpose of identifying opportunities for improvement.

The continuous improvement process will be designed to:

- Identify areas of opportunity for improvement of environmental management and performance
- Determine the cause or causes of non-conformances and deficiencies
- Develop and implement a plan of corrective and preventative action to address any non-conformances and deficiencies
- Verify the effectiveness of the corrective and preventative actions through weekly inspections, visual observations and implementation of the Air Quality Monitoring Program (Appendix A)
- Document any changes in procedures resulting from process improvement
- Make comparisons with objectives and targets.

8.2 UPDATE AND AMENDMENT

The processes described in Section 1.5 and Section 9 of the CEMP may result in the need to update or revise this plan. This will occur as needed.

Only the Environment Manager, or delegate, has the authority to change any of the environmental management documentation.

A copy of the updated plan and changes will be distributed to all relevant stakeholders in accordance with the approved document control procedure – refer to Section 1.3 and 1.4 of the CEMP.

APPENDICES



APPENDIX A CONSTRUCTION AIR QUALITY MONITORING PROGRAM

Air Quality Monitoring Program

FERROVIAL GAMUDA JOINT VENTURE

THIS PAGE IS LEFT INTENTIONALLY BLANK

DOCUMENT DETAILS

Document Title	Air Quality Monitoring Program
Project Name	Coffs Harbour Bypass
Client	Transport for New South Wales
Application No.	SSI-7666
Principal Contractor	Ferrovial Gamuda Joint Venture

DOCUMENT AUTHORISATION

	Name	Position	Signature	Date
Prepared by	Reina Iligan	FGJV Environment Coordinator		
Reviewed by	Erran Woodward	FGJV Approvals Lead		
Approved by	Hari Corliss	FGJV Environment & Sustainability Manager		
Approved by	Daniel Perez	FGJV Project Director		
Approved by	Scott Lawrence	TfNSW Representative		
Endorsed by	Duncan Thomson	Environmental Representative		

VERSION CONTROL

Revision	Date	Description	Approval
A	31/08/2022	FGJV Draft for TfNSW and ER Review	Hari Corliss
B	10/10/22	Updated to address ER comments, for ER endorsement	Hari Corliss
C	30/11/2022	Updated to address DPE comments	Hari Corliss

DISTRIBUTION OF CONTROLLED COPIES

This CEMP is available to all personnel and sub-contractors via the project document control management system. An electronic copy can be found on the project website.

The document is uncontrolled when printed. One controlled hard copy of the CEMP and supporting documentation will be maintained by the Quality Manager at the project office and on the project website.

Copy No.	Issued to	Version
1		
2		
3		
4		
5		

GLOSSARY/ABBREVIATIONS

Abbreviation	Expanded Text
CAQMP	Construction Air Quality Management Sub-Plan
BOM	Australian Government Bureau of Meteorology
CEMP	Construction Environmental Management Plan
DAWE	Department of Agriculture, Water and Environment
DDG	Dust Depositional Gauge
DPE	Department of Planning and Environment
DPE, EESG	Department of Planning and Environment – Environment, Energy and Science Group
EIS	Environmental Impact Statement
EP&A Act	Environmental Planning and Assessment Act 1979
EPBC Act	Environmental Protection and Biodiversity Conservation Act 1999
EPA	NSW Environment Protection Authority
EWMS	Environmental Work Method Statements
FGJV	Ferrovial Gamuda Joint Venture
GREP	Government Resource Efficiency Policy
MCoA	Minister's Condition of Approval
NEPM	National Environment Protection Measures
PM _{2.5}	Fine Particulate Matter
PM ₁₀	Particulate Matter
POEO Act	Protection of the Environment Operations Act 1997
REMMs	Revised Environmental Management Measures
TfNSW	Transport for NSW

CONTENTS

1	Introduction	6
1.1	Context	6
1.2	Background	6
2	Environmental Requirements	7
2.1	Ministers Conditions of Approval	7
2.2	Environmental Management Measures	8
2.3	Environmental protection license	8
2.4	Consultation	8
3	Existing Environment	9
3.1	Ambient Air Quality Conditions	9
3.2	BASELINE Depositional dust gauge data	9
4	Monitoring Methodology	10
4.1	Dust Deposition Gauge Monitoring	10
4.2	total suspended particulates	14
4.3	Air Quality Criteria	15
5	Reporting	17
	Appendices	18
	Appendix A background dust deposition gauge data	19
	Appendix B Dust Deposition Gauge Procedure	35
	Appendix C Dust Deposition Gauge Field Sampling Sheet	36
	Appendix D Dust monitoring locations and sensitive receivers	37

TABLES

Table 1	Ministers Conditions of Approval relevant to Air Quality Monitoring Program.....	7
Table 2	Environmental Management Measures Relevant to this Air Quality Monitoring Program.....	8
Table 7	Korora air quality monitoring results	9
Table 3	Dust Depositional Gauge Monitoring Locations	10
Table 4	total Suspended Particulates Monitoring Locations.....	14
Table 2	total suspended Particulates air quality criteria during construction.....	15
Table 3	Air quality monitoring criteria for deposited dust ^a	15

1 INTRODUCTION

1.1 CONTEXT

This Air Quality Monitoring Program is an appendix to the Construction Air Quality Management Sub Plan (CAQMP) that forms part of the Construction Environmental Management Plan (CEMP) for the Coffs Harbour Bypass (the Project).

The purpose of this Air Quality Monitoring Program is to provide details on the baseline data available for Coffs Harbour, the parameters, frequency and location of monitoring required for the Project. This program will also outline the reporting requirements and any additional management and mitigation measures to be implemented on the Project. Monitoring undertaken during the construction phase of the project will verify the effectiveness of mitigation and management measures implemented to minimise air quality issues on the Project.

1.2 BACKGROUND

The Coffs Harbour Bypass EIS (Chapter 21) considered the potential air quality impacts during the construction of the project. The background of the Project is described in Section 1 of the CEMP.

The Project includes the construction of a 14-kilometre bypass of Coffs Harbour, including a 12-kilometre new build from south of Englands Road to Korora Hill in the north and a two-kilometre upgrade of the existing highway between Korora Hill and Sapphire. The Project would provide a four-lane divided highway that bypasses Coffs Harbour, passing through the North Boambee Valley, Roberts Hill and then traversing the foothills of the Coffs Harbour basin to the west and north to Korora Hill.

2 ENVIRONMENTAL REQUIREMENTS

Refer to the CAQMP for full list of legislation, regulation and EMMs. Table 1 details the MCoA specific to the Air Quality Monitoring Program.

2.1 MINISTERS CONDITIONS OF APPROVAL

TABLE 1 MINISTERS CONDITIONS OF APPROVAL RELEVANT TO AIR QUALITY MONITORING PROGRAM

CoA No.	Condition Requirements	Document Reference				
C13	The Construction Monitoring Programs in Table 4 must be prepared in consultation with the relevant government agencies identified for each to compare actual performance of construction of the CSSI against the performance predicted in documents listed in Condition A1 or in the CEMP.	Air Quality Monitoring Program				
	<table border="1"> <thead> <tr> <th></th> <th>Required Construction Monitoring Programs</th> <th>Relevant government agencies to be consulted for each Construction Monitoring Program</th> </tr> </thead> <tbody> <tr> <td>(a)</td> <td>Air quality</td> <td>EPA, DPI Agriculture, Council</td> </tr> </tbody> </table>			Required Construction Monitoring Programs	Relevant government agencies to be consulted for each Construction Monitoring Program	(a)
	Required Construction Monitoring Programs	Relevant government agencies to be consulted for each Construction Monitoring Program				
(a)	Air quality	EPA, DPI Agriculture, Council				
C14	Each Construction Monitoring Program must provide:					
	(a) Details of baseline data available;	Section 3.2				
	(b) Details of baseline data to be obtained and when;	Section 3.2				
	(c) Details of all monitoring of the project to be undertaken;	Section 4				
	(d) The parameters of the project to be monitored;	Section 4				
	(e) The frequency of monitoring to be undertaken;	Section 4				
	(f) The location of monitoring;	Section 4				
	(g) The reporting of monitoring results;	Section 5				
	(h) Procedures to identify and implement additional mitigation measures where results of monitoring are unsatisfactory; and	Section 4.3				
(i) Any consultation to be undertaken in relation to the monitoring programs.	Section 2.4					
C15	The Construction Monitoring Programs must be developed in consultation with relevant government agencies as identified in Condition C13 of this approval and must include information requested by an agency to be included in a Construction Monitoring Programs during such consultation. Details of all information requested by an agency including copies of all correspondence from those agencies, must be provided with the relevant Construction Monitoring Program.	Consultation records to be provided to DPE				
C16	The Construction Monitoring Programs must be endorsed by the ER and then submitted to the Planning Secretary for approval at least one month before the commencement of construction.	Document control and approvals detailed in CAQMP version control table				
C17	Construction must not commence until the Planning Secretary has approved all of the required Construction Monitoring Programs, and all relevant baseline data for the specific construction activity has been collected.	Noted				
C18	The Construction Monitoring Programs, as approved by the Planning Secretary including any minor amendments approved by the ER must be implemented for the duration of	Document control and approvals detailed in				

	construction and for any longer period set out in the monitoring program or specified by the Planning Secretary, whichever is the greater.	CAQMP version control table
C19	The results of the Construction Monitoring Programs must be submitted to the Planning Secretary, and relevant regulatory agencies, for information in the form of a Construction Monitoring Report at the frequency identified in the relevant Construction Monitoring Program.	Section 5

2.2 ENVIRONMENTAL MANAGEMENT MEASURES

TABLE 2 ENVIRONMENTAL MANAGEMENT MEASURES RELEVANT TO THIS AIR QUALITY MONITORING PROGRAM

Outcome	Ref#	Commitment	Timing	CAQMP Reference
Dust impacts - Agriculture	AG06	Real time dust monitoring will be carried out at representative locations of dust sensitive agricultural receivers along the project alignment to allow for the timely management of dust generation on-site and to minimise potential impacts. The representative locations of dust sensitive agricultural receivers will be determined during detailed design and will include the Oz Group Packhouse. Monitoring will be carried out in accordance with the Approved Methods for the sampling and analysis for air pollutants in NSW (EPA 2017a) where applicable.	Prior to and during construction	Section 4

2.3 ENVIRONMENTAL PROTECTION LICENSE

An Environmental Protection License (EPL) will be sought for the Project. Upon award, this Plan will be updated to reflect any license requirements or conditions applicable to air quality.

2.4 CONSULTATION

In accordance with MCoA C13, this Air Quality Monitoring Program has been developed in consultation with the relevant government agencies including:

- NSW EPA
- DPI Agriculture
- Coffs Harbour Council.

Consultation will be undertaken with the abovementioned stakeholders as required throughout the pre-construction and construction phases of the project.

3 EXISTING ENVIRONMENT

3.1 AMBIENT AIR QUALITY CONDITIONS

There is limited information about local air quality in the vicinity of the Project. Long-term monitoring is not usually undertaken outside metropolitan and/or industrial areas, because pollutants typically do not exist in concentrations that would cause adverse environmental or health impacts. However, there has been short-term air quality monitoring adjacent to a dual carriageway section of the Pacific Highway at Korora, which is located within the construction corridor of the Coffs Harbour bypass. A monitoring station was established at Korora to monitor the background ambient air quality from October 2005 to January 2007. (Sapphire to Woolgoolga Pacific Highway Upgrade, Korora Air Quality Monitoring Paper, Connell Wagner, 2007). Table 7 presents the monitoring results from the monitoring station at Korora in comparison to the NEPM goals.

TABLE 3 KORORA AIR QUALITY MONITORING RESULTS

Pollutant	Averaging period	NEPM Goals		Korora monitoring results	
		Maximum Concentration	10-year goal (max allowable exceedance)	Maximum recorded concentration	Average recorded concentration
National standards and goals for ambient air quality					
Carbon monoxide	8 hr	9.0 ppm (10 mg/m ³)	1 day a year	0.2 ppm (0.3 mg/m ³)	0.03 ppm (0.04 mg/m ³)
Nitrogen dioxide	1 hr	0.12 ppm (246 µg/m ³)	1 day a year	0.036 ppm (73.8 µg/m ³)	0.004 ppm (9.2 µg/m ³)
Particles as PM₁₀	1 day	50 µg/m ³	5 days a year	37.8 µg/m ³	20.3 µg/m ³
Advisory reporting goals					
PM_{2.5}	1 day	25 µg/m ³	Gather data to facilitate review of a goal	15.4 µg/m ³	7.7 µg/m ³

3.2 BASELINE DEPOSITIONAL DUST GAUGE DATA

Background monitoring using DDGs has been undertaken in the pre-construction phase of the project. DDG data has been recorded by TfNSW since September 2021, to allow discussion and comparison between preconstruction and construction monitoring results. This is included in graph format, along with the location of the depositional dust gauges in Appendix A.

Where an exceedance of monitoring criteria is identified, background monitoring information will be used to determine if this is consistent with pre-construction conditions, and if the construction can be considered to be the cause of the identified exceedance.

Baseline monitoring will continue until the commencement of construction, this may include some early works activities in some locations. Construction is taken to be the commencement of construction under an approved CEMP, which is proposed to commence in March 2023.

On completion of pre-construction monitoring, the baseline trigger will be determined prior to the commencement of construction, and will be included into a database within which all data will be recorded. The database will be set up to automatically identify non-compliances with this pre-set figure. Additional mitigation measures will be implemented where results of monitoring are unsatisfactory.

4 MONITORING METHODOLOGY

Air quality will be monitored for the duration of the construction period of the project to provide verification of the effectiveness of mitigation and management measures implemented to minimise air quality issues. Based on the predicted construction air quality impacts described in the EIS, air quality monitoring requirements for the project comprises two primary monitoring functions.

4.1 DUST DEPOSITION GAUGE MONITORING

Fifteen dust deposition dust gauges (DDGs) have been installed adjacent to the project alignment at locations considered to be representative of the human and ecological receptors identified in the EIS. Monitoring location mapping have been provided within Table 3.

The dust monitoring locations have been selected based on satisfaction of the criteria prescribed in the *Australian Standard, A/NZS 3580.1.1:2007: Methods for sampling and analysis of ambient air, Part 1.1: Guide to siting air monitoring equipment*. Installation and operation of the DDGs is to be in accordance with the Dust Deposition Gauge Procedure and Field Sampling Sheet – Appendix B and C respectively.

During construction, the monitoring locations specified in Table 3 may be altered slightly so as to not be impacted by construction activities but maintain the same level of sample collection. Any changes to the locations in Table 3 will be made in consultation with the ER and updated into this document. Figures of dust monitoring locations in relation to nearby sensitive receivers are provided in Appendix D.





Data will be obtained on a monthly basis during construction.

TABLE 4 DUST DEPOSITIONAL GAUGE MONITORING LOCATIONS

Dust Deposition Gauge Number	Chainage/Location Alignment Side	Target Sensitive Receiver Types	Monitoring Location Mapping DDG Site shown as (red diamond)
DDG1	10000 West	Human / Ecological / Agricultural	
DDG2	10750 East (PM10 and PM2.5 Monitoring Location -Site 2)	Ecological / Agricultural	

<p>DDG3</p>	<p>12250 East</p>	<p>Human</p>	
<p>DDG4</p>	<p>14500 East</p>	<p>Ecological / Agricultural</p>	
<p>DDG5</p>	<p>14800 East</p>	<p>Human</p>	
<p>DDG6</p>	<p>15500 East</p>	<p>Human</p>	

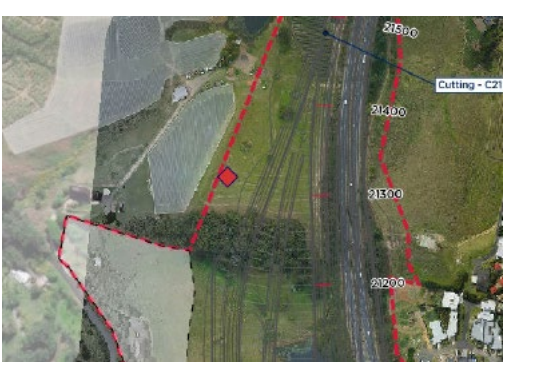
<p>DDG7</p>	<p>16600</p>	<p>Human</p>	
<p>DDG8</p>	<p>18000</p>	<p>Human</p>	
<p>DDG9</p>	<p>18500 West</p>	<p>Ecological / Agricultural</p>	
<p>DDG10</p>	<p>19700 East</p>	<p>Ecological / Agricultural</p>	

<p>DDG11</p>	<p>19700 West</p>	<p>Ecological / Agricultural</p>	
<p>DDG12</p>	<p>21000 East</p>	<p>Human</p>	
<p>DDG13</p>	<p>21300 West (PM10 and PM2.5 Monitoring Location -Site 1)</p>	<p>Ecological / Agricultural</p>	
<p>DDG14</p>	<p>22000 East</p>	<p>Human / Ecological / Agricultural</p>	

DDG15	23000	Human	
-------	-------	-------	--

4.2 TOTAL SUSPENDED PARTICULATES

In accordance with the REMM AG06 in the EIS Submissions Report, continuous particulate dust monitors are to be installed at two representative locations to monitor potential construction dust impacts to agricultural production and processing.

Total suspended particulate monitors will operate in a real time capacity. These will be reviewed monthly (at the same time as DDG collection) and also in response to complaint or during adverse weather conditions.

Monitoring will be carried out in accordance with the Approved Methods for the sampling and analysis for air pollutants in NSW (EPA 2017a) at the locations detailed in Table 4 and below.

TABLE 5 TOTAL SUSPENDED PARTICULATES MONITORING LOCATIONS

Site	Chainage/Location Alignment Side	Target Sensitive Receiver Types	Monitoring Location Mapping DDG Site shown as (yellow diamond)
Site 1 – Korora Hill	21300 West <ul style="list-style-type: none"> • DDG13 Monitoring Location (red diamond) 	Ecological / Agricultural This site was selected as it is adjacent to the largest blueberry agricultural production area nearby the project alignment	

<p>Site 2 – OzGroup Blueberry Processing Facility</p>	<p>10750 East</p> <ul style="list-style-type: none"> • DDG13 Monitoring Location (red diamond) 	<p>Ecological / Agricultural</p> <p>This location was selected due to concerns raised in EIS submissions that the large processing facility may be impacted by dust as a result of nearby road construction.</p>	
--	---	--	--

4.3 AIR QUALITY CRITERIA

In NSW, the statutory methods that are used to assess the air pollution impacts of projects are detailed in the Approved Methods for the Modelling and Assessment of Air Pollutants in NSW (EPA 2017a). The relevant air quality standards are shown in Table 2 and Table 3 that form the assessment criteria for dust monitoring to be undertaken. Total Suspended Particulates and deposited dust is to be monitored.

TABLE 6 TOTAL SUSPENDED PARTICULATES AIR QUALITY CRITERIA DURING CONSTRUCTION

Pollutant	Averaging period	Standard (µg/m ³)
Total Suspended Particulates	Annual	90

TABLE 7 AIR QUALITY MONITORING CRITERIA FOR DEPOSITED DUST^a

Pollutant	Annual Concentration		Source
Deposited dust ^b	2 g/m ² /month ^c	4 g/m ² /month ^d	NERDDC (1998)

Note:
a. Adapted from EPA NSW guideline; Approved Methods for the Modelling and Assessment of Air Pollutants in New South Wales (EPA 2017).
b. Dust is assessed as insoluble solids as defined by AS 3580.10.1-1991 (AM-19).
c. Maximum increase in deposited dust level.
d. Maximum total deposited dust level.

The 2g/m²/month criteria is used as a maximum increase value when baseline data on deposited dust levels exists, while the 4g/m²/month criteria is used when no baseline data exists. Annualised averages are to form the basis of compliance, with monthly results providing opportunity for compliance checks on a monthly basis.

Data from monthly DDG monitoring will be incorporated into a database and assessed against baseline criteria. Where exceedances are identified and confirmed to be caused by construction activities, the construction methodology and appropriateness of mitigation measures will be reviewed by the Environment Manager and relevant construction lead (in accordance with section 7.5 and 8.1 of the Air Quality Management plan), and additional measures will be implemented where reasonable and feasible. Any changes will be captured in EWMS where applicable, and be updated into the CAQMP if required.

Mitigation measures to be implemented are detailed in the CAQMP, to which this Monitoring Program will be appended.

5 REPORTING

Results of depositional and particulate dust monitoring are to be reported on a 6-monthly basis, this report is to be provided to TfNSW and regulatory agencies as required by an EPL. The 6-monthly report will include the following details:

- A summary of the monitoring undertaken
- An assessment of monitoring results assessed against relevant criteria including annualised averages
- Provide details of any exceedance of assessment criteria
- Provide discussion of monthly and annualised monitoring results against the baseline data obtained during the preconstruction stage of the project
- Provide details of construction activities or circumstances that may have contributed to the exceedance
- Details of corrective actions implemented to prevent the recurrence of exceedance of assessment criteria

APPENDICES



APPENDIX A BACKGROUND DUST DEPOSITION GUAGE DATA

Dust Deposition Gauge 1

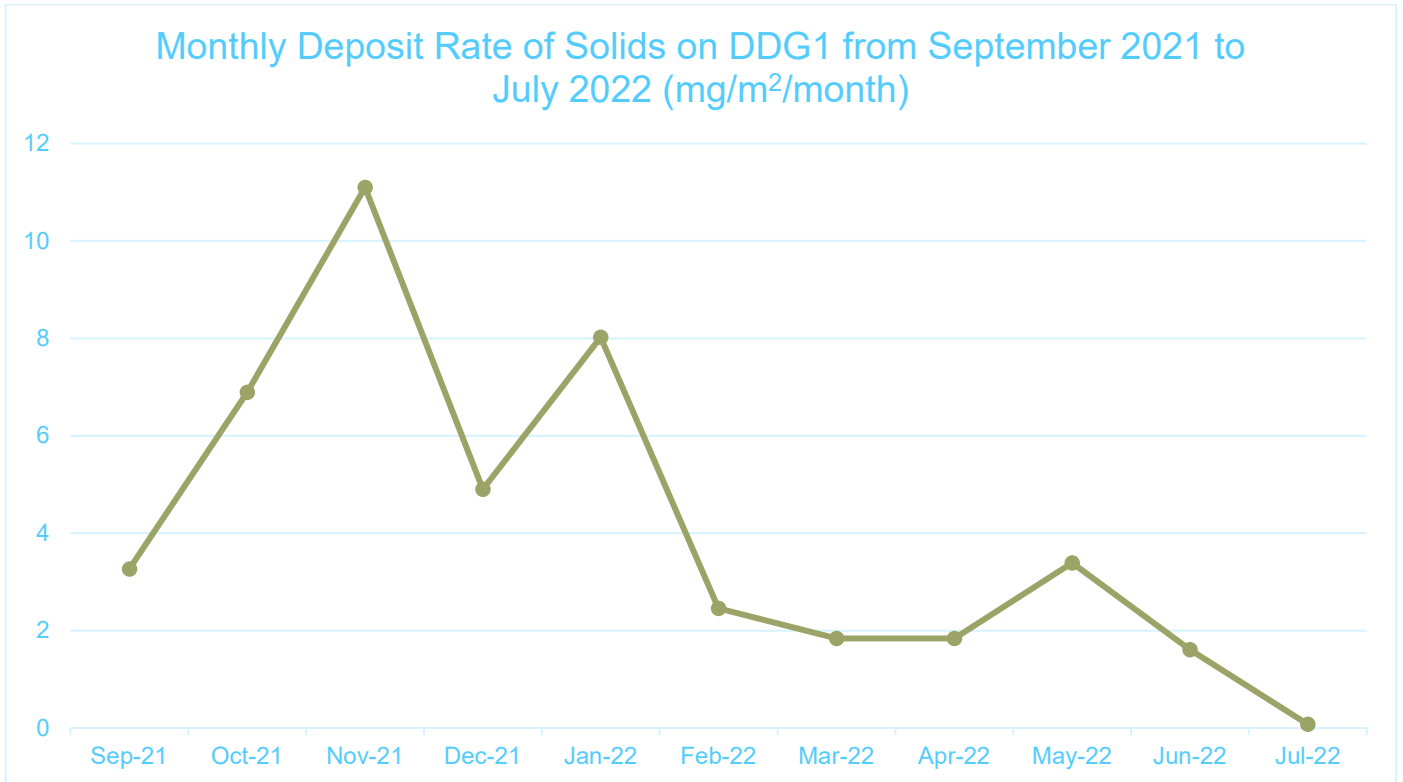

Chainage/Location Alignment Side	Target Sensitive Receiver Types	Monitoring Location Mapping DDG Site shown as (red diamond)
10000 West	Human / Ecological / Agricultural	

Dust Deposition Gauge 2

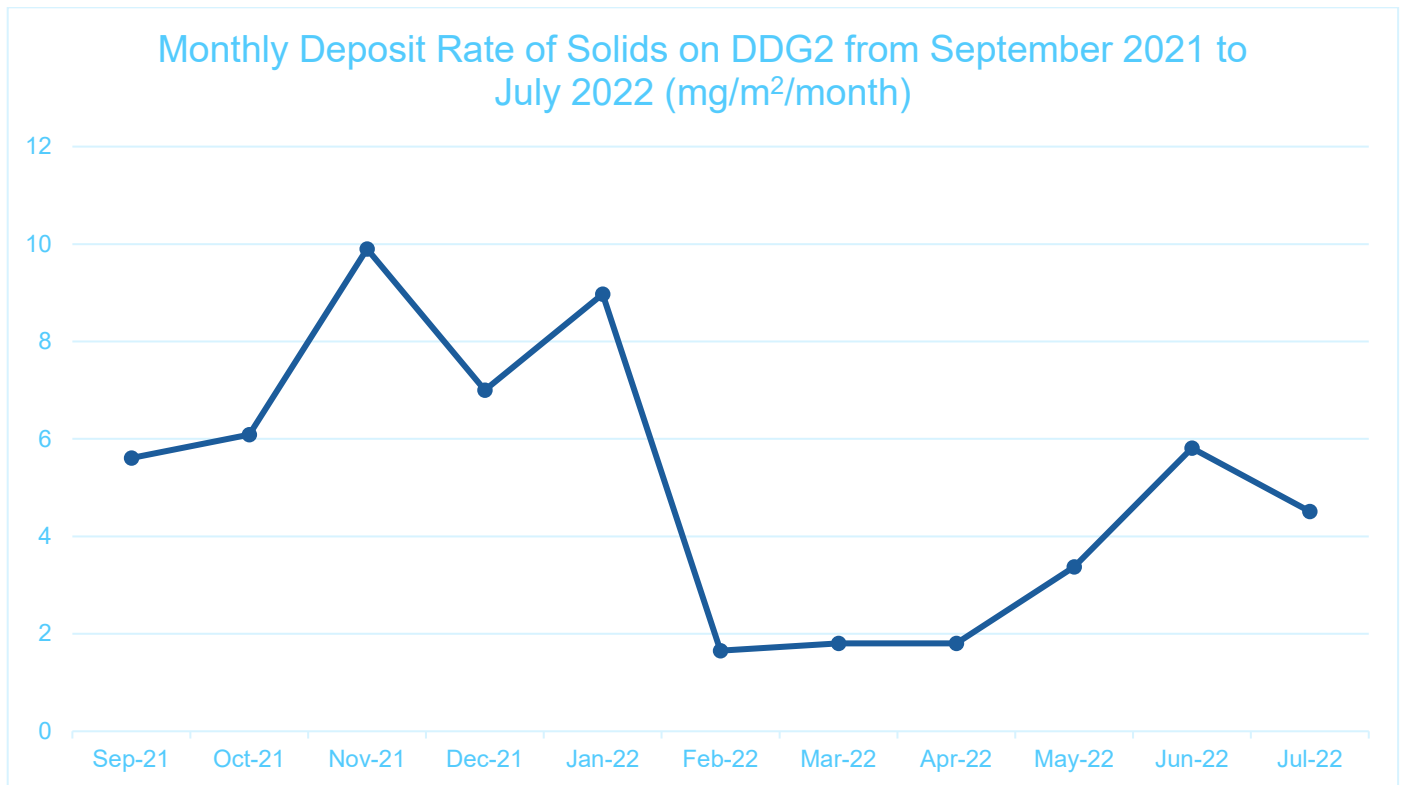

Chainage/Location Alignment Side	Target Sensitive Receiver Types	Monitoring Location Mapping DDG Site shown as (red diamond)
10750 East (PM10 and PM2.5 Monitoring Location -Site 2)	Ecological / Agricultural	

Dust Deposition Gauge 3

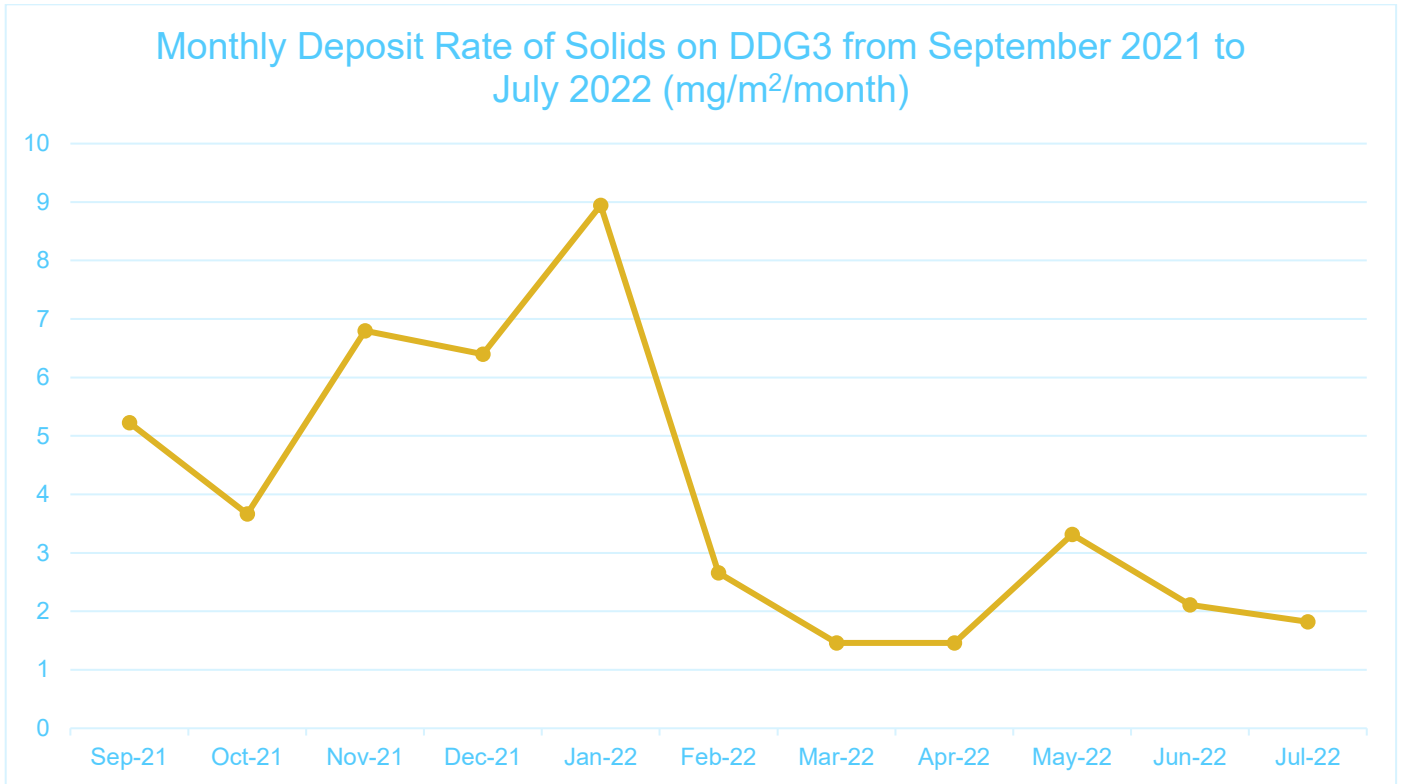

Chainage/Location Alignment Side	Target Sensitive Receiver Types	Monitoring Location Mapping DDG Site shown as (red diamond)
12250 East	Human	

Dust Deposition Gauge 4

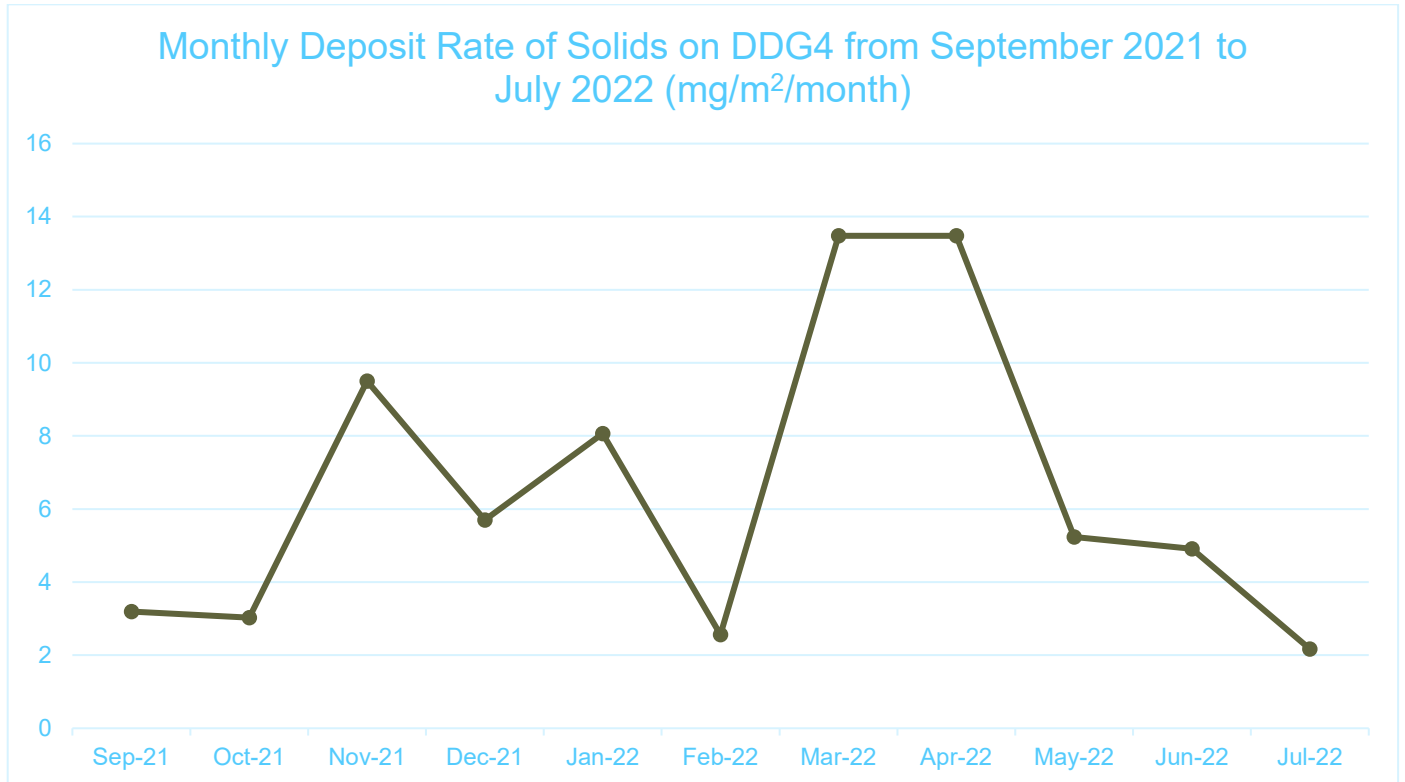

Chainage/Location Alignment Side	Target Sensitive Receiver Types	Monitoring Location Mapping DDG Site shown as (red diamond)
14500 East	Ecological / Agricultural	

Dust Deposition Gauge 5

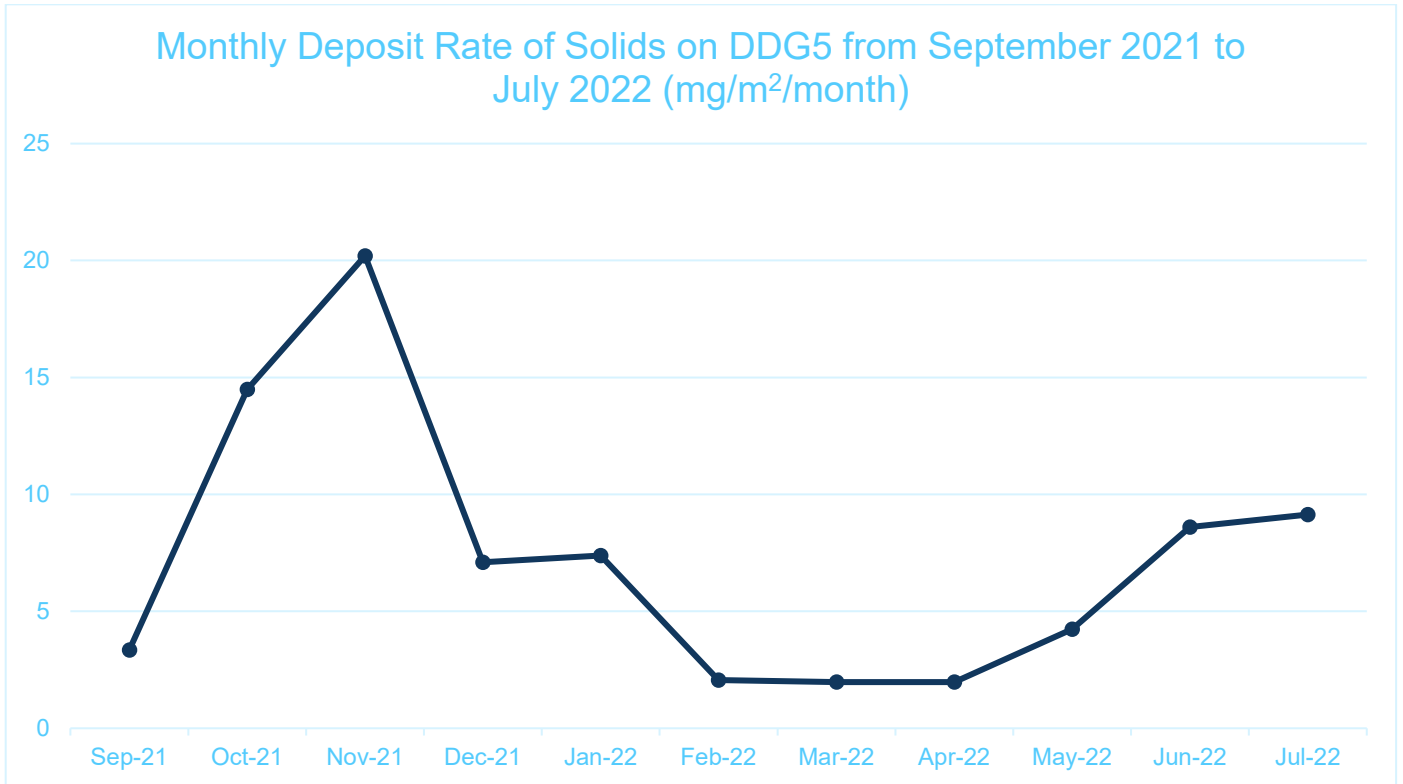

Chainage/Location Alignment Side	Target Sensitive Receiver Types	Monitoring Location Mapping DDG Site shown as (red diamond)
14800 East	Human	

Dust Deposition Gauge 6

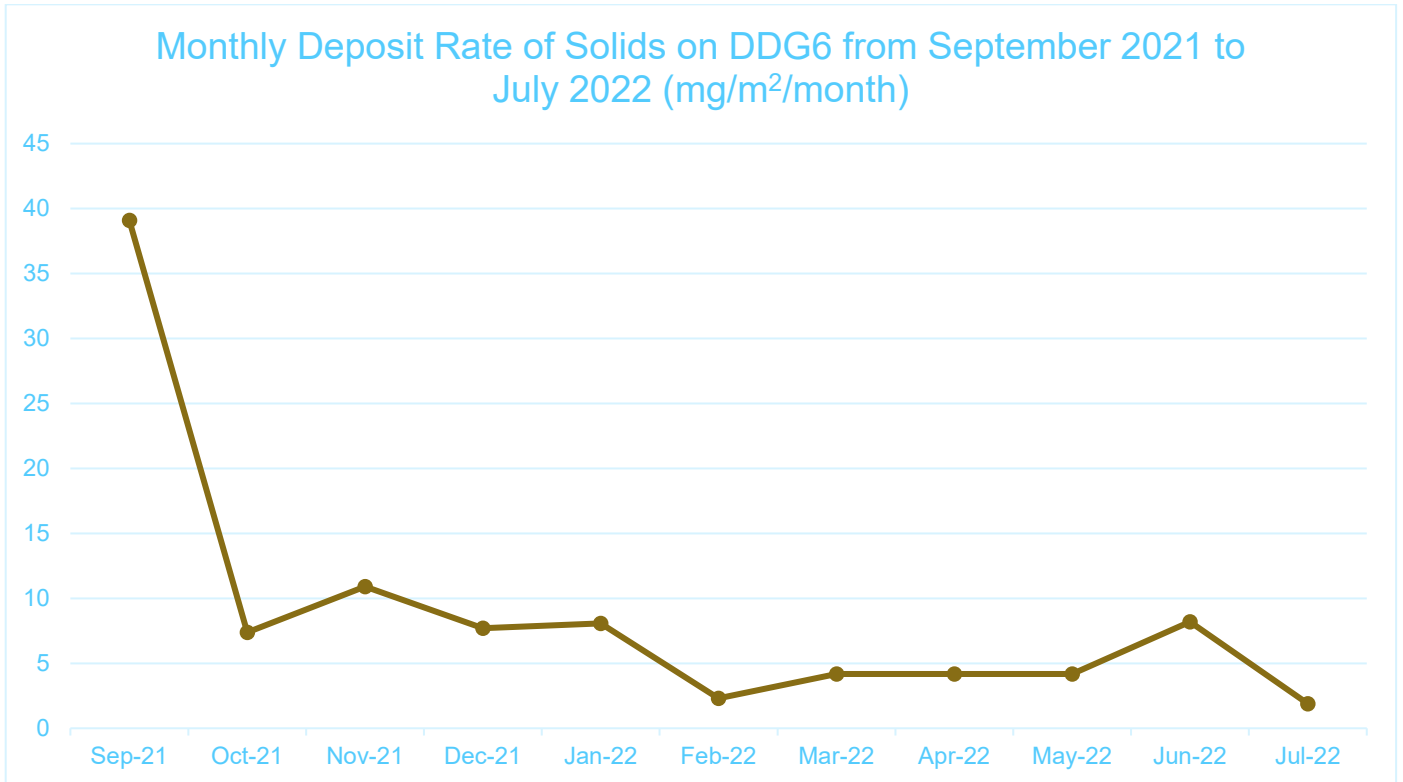

Chainage/Location Alignment Side	Target Sensitive Receiver Types	Monitoring Location Mapping DDG Site shown as (red diamond)
15500 East	Human	

Dust Deposition Gauge 7

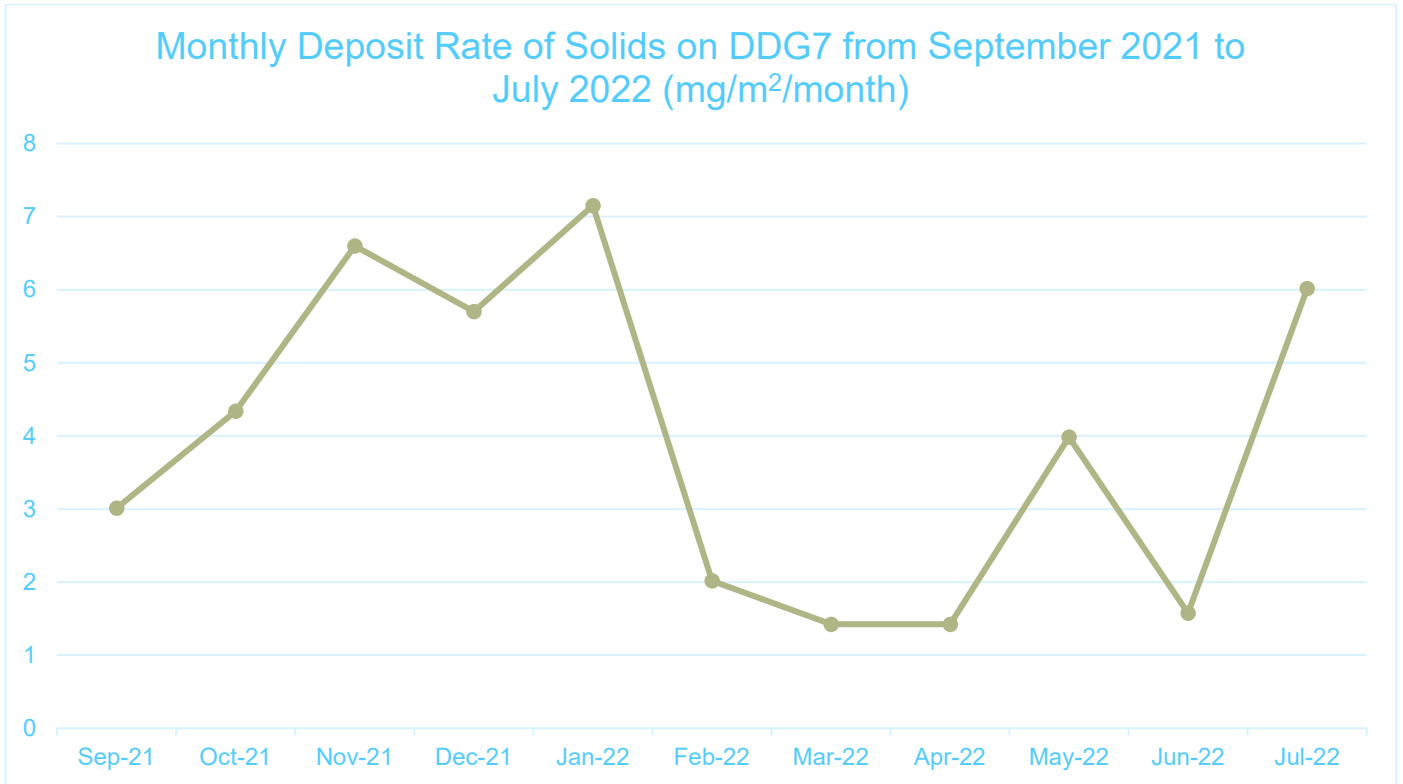

Chainage/Location Alignment Side	Target Sensitive Receiver Types	Monitoring Location Mapping DDG Site shown as (red diamond)
16600	Human	

Dust Deposition Gauge 8

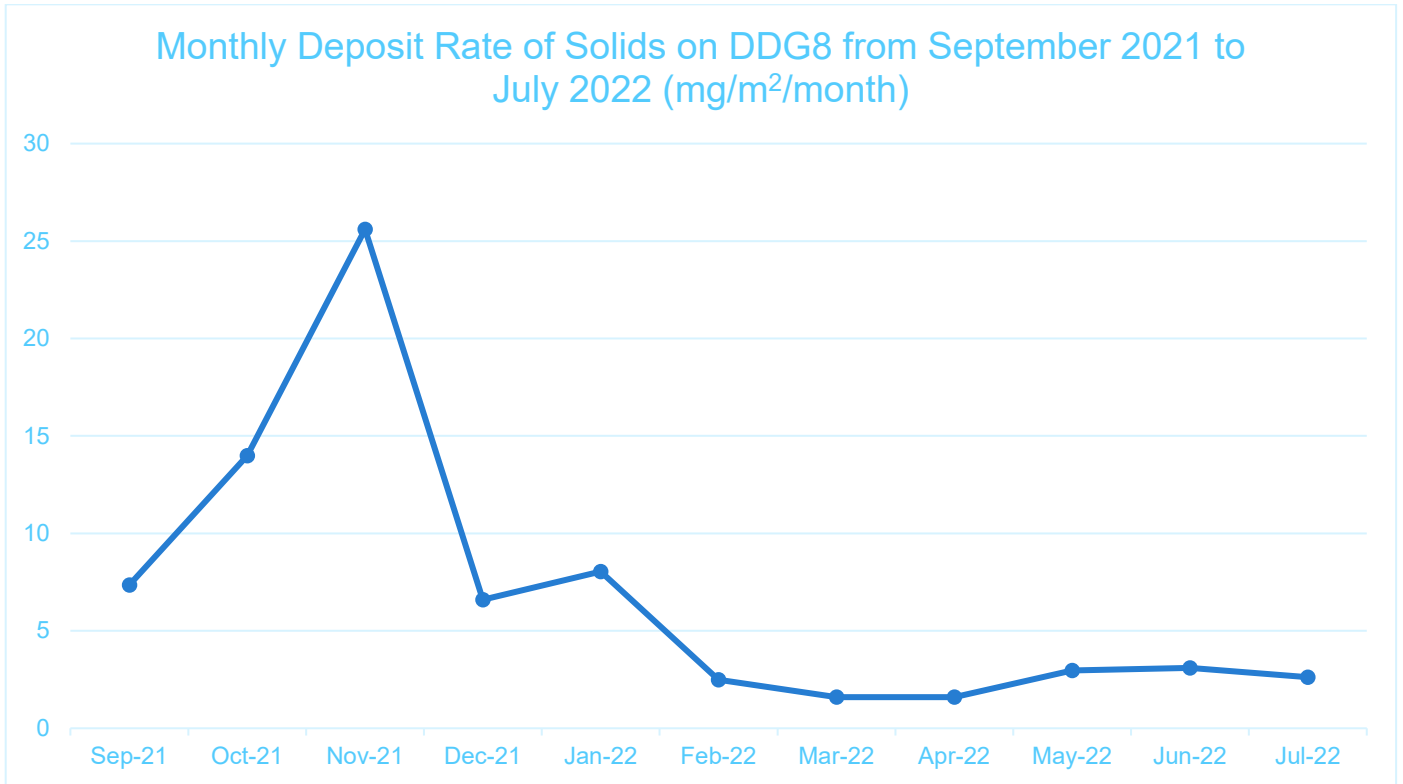

Chainage/Location Alignment Side	Target Sensitive Receiver Types	Monitoring Location Mapping DDG Site shown as (red diamond)
18000	Human	

Dust Deposition Gauge 9

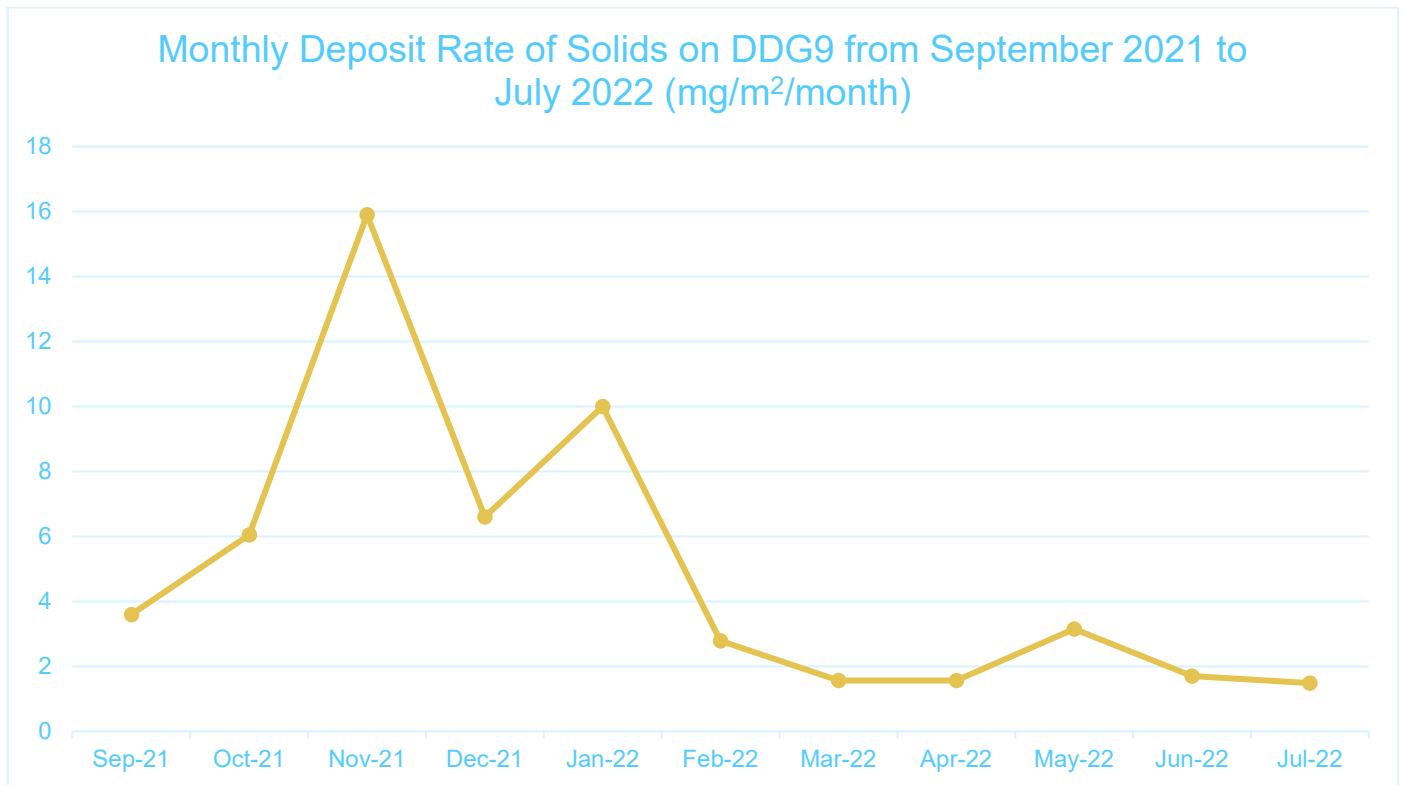

Chainage/Location Alignment Side	Target Sensitive Receiver Types	Monitoring Location Mapping DDG Site shown as (red diamond)
18500 West	Ecological / Agricultural	

Dust Deposition Gauge 10

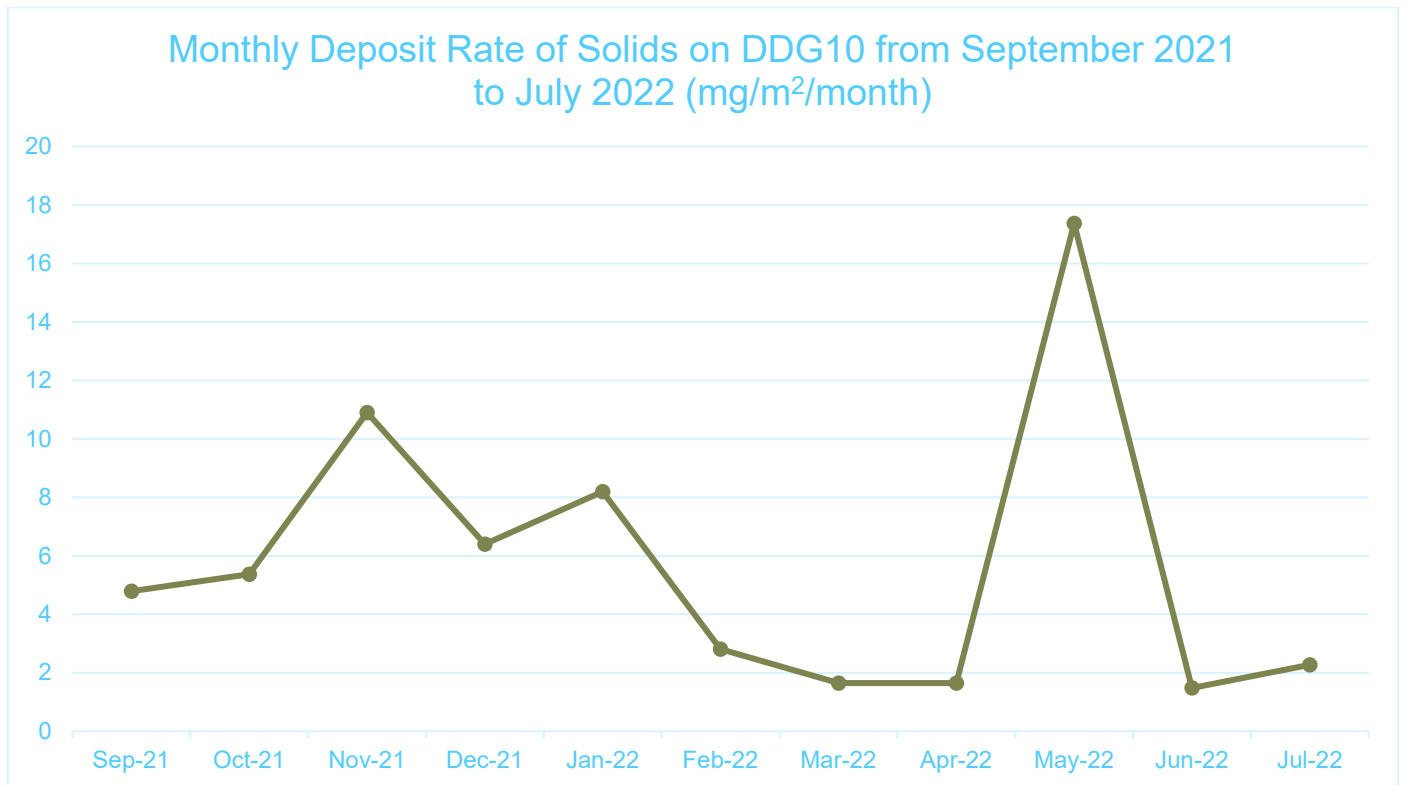

Chainage/Location Alignment Side	Target Sensitive Receiver Types	Monitoring Location Mapping DDG Site shown as (red diamond)
19700 East	Ecological / Agricultural	

Dust Deposition Gauge 11

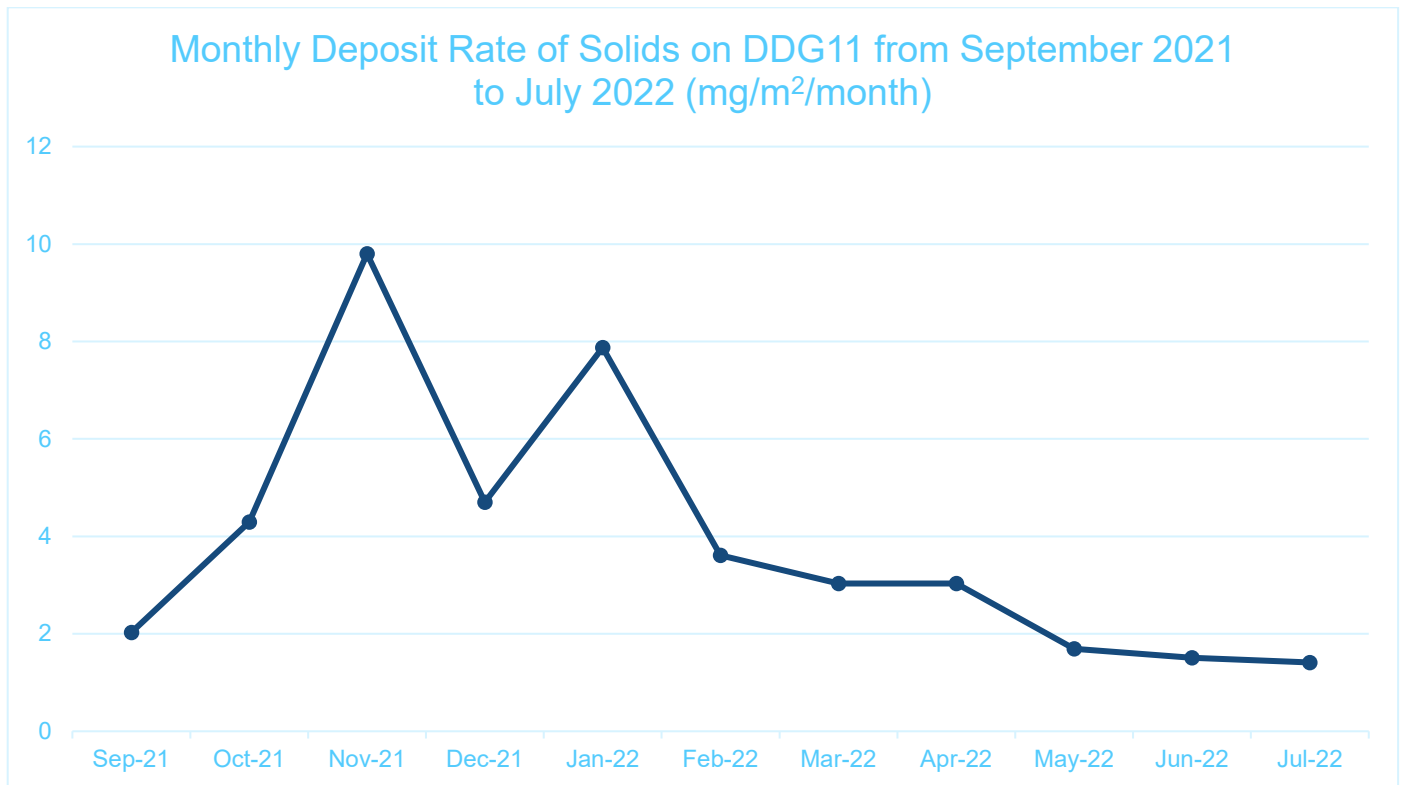

Chainage/Location Alignment Side	Target Sensitive Receiver Types	Monitoring Location Mapping DDG Site shown as (red diamond)
19700 West	Ecological / Agricultural	

Dust Deposition Gauge 12

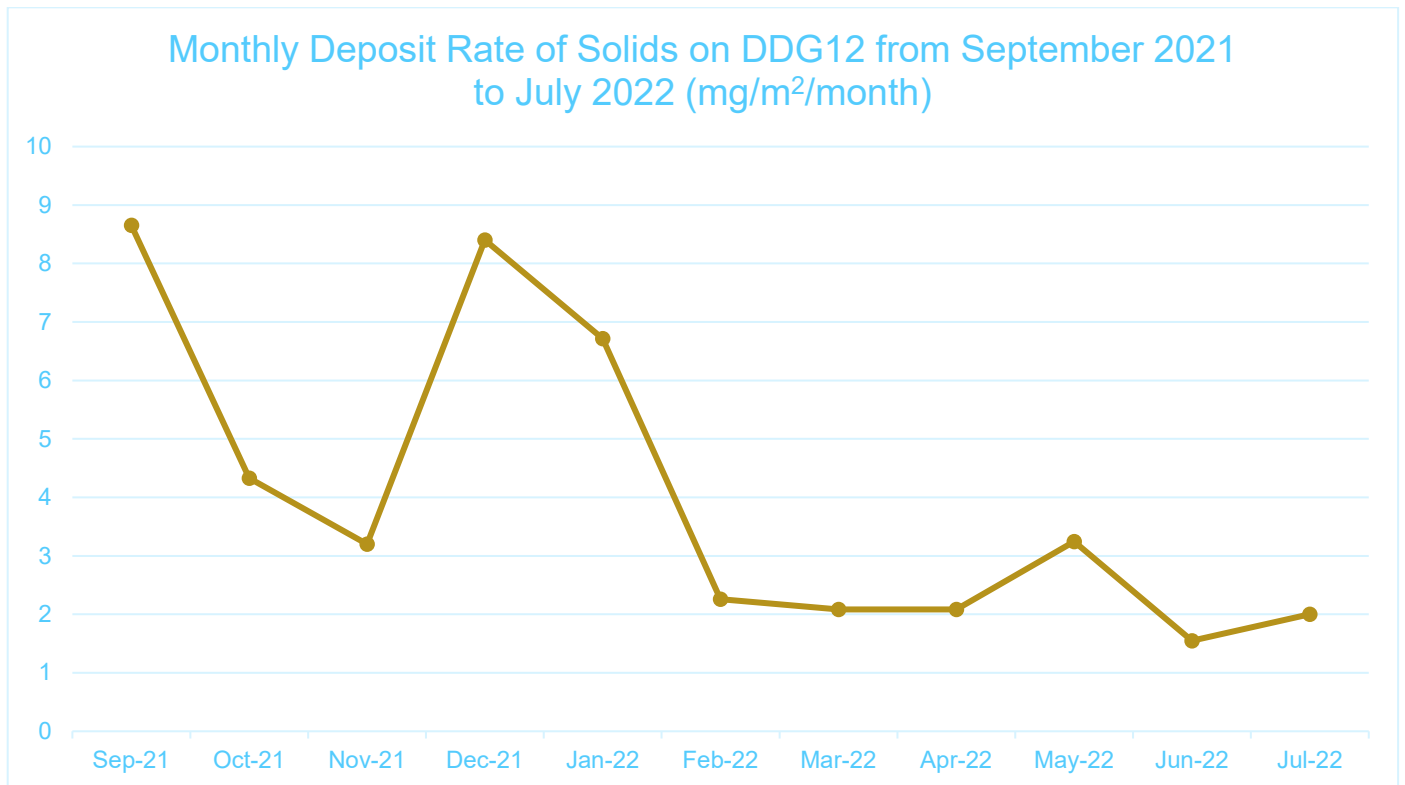

Chainage/Location Alignment Side	Target Sensitive Receiver Types	Monitoring Location Mapping DDG Site shown as (red diamond)
21000 East	Human	

Dust Deposition Gauge 13

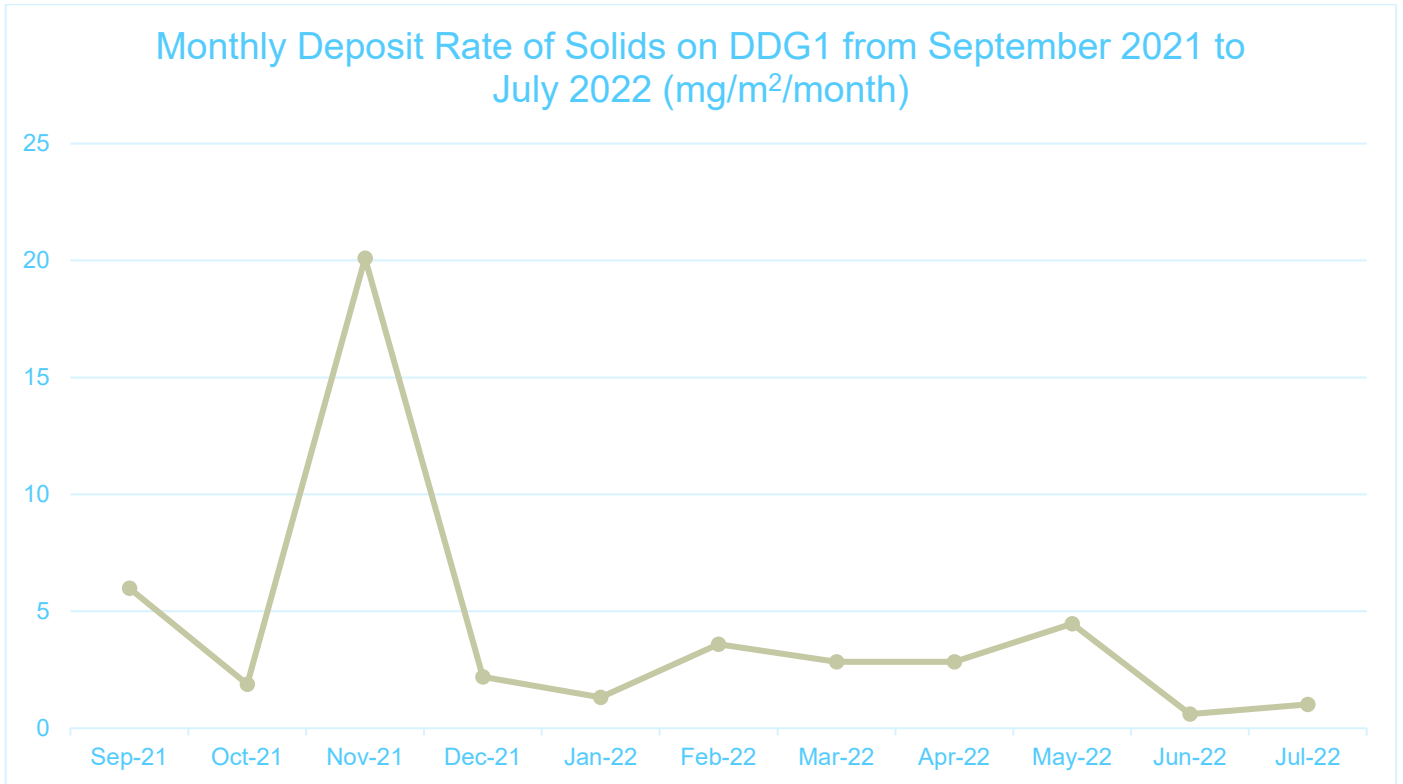

Chainage/Location Alignment Side	Target Sensitive Receiver Types	Monitoring Location Mapping DDG Site shown as (red diamond)
21300 West (PM10 and PM2.5 Monitoring Location - Site 1)	Ecological / Agricultural	

Dust Deposition Gauge 14

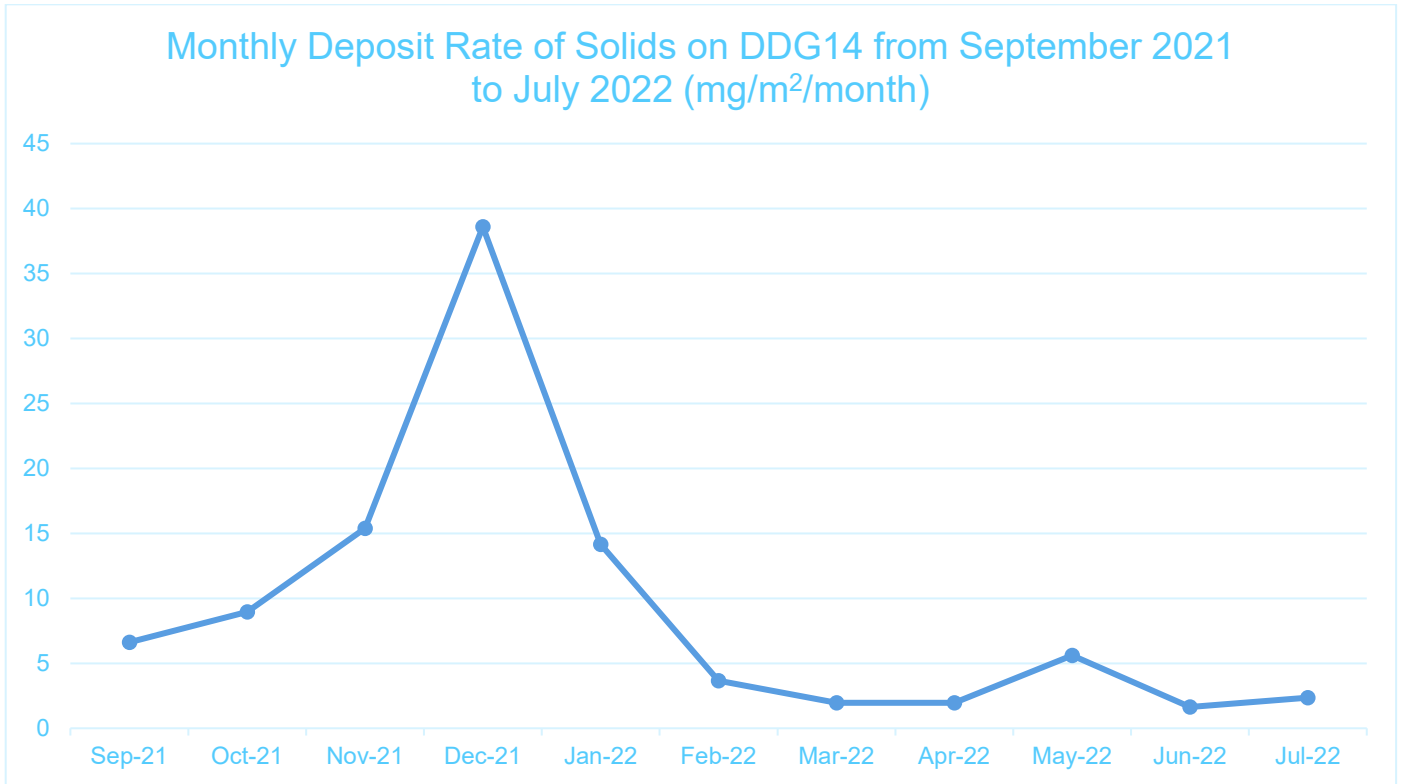

Chainage/Location Alignment Side	Target Sensitive Receiver Types	Monitoring Location Mapping DDG Site shown as (red diamond)
22000 East	Human / Ecological / Agricultural	

Dust Deposition Gauge 15

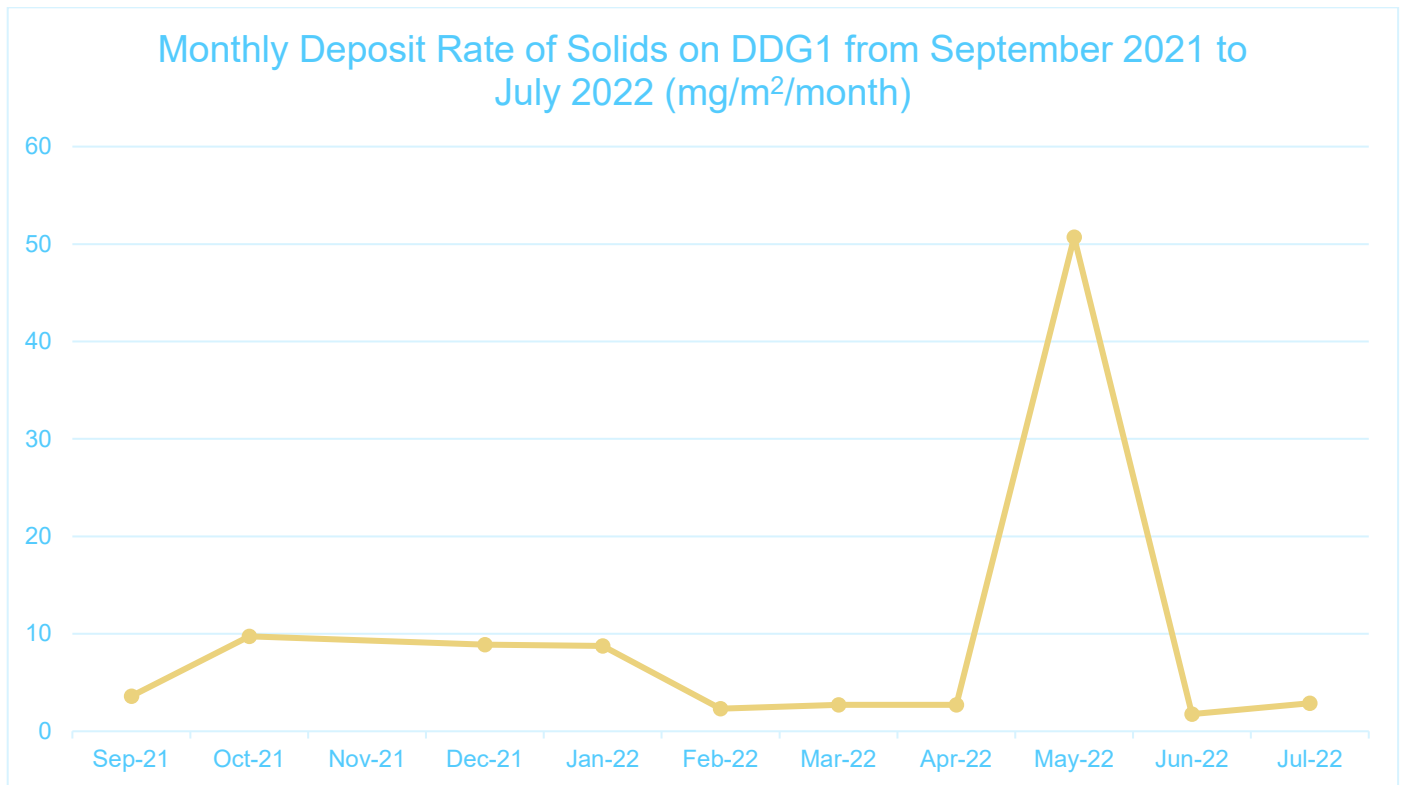

Chainage/Location Alignment Side	Target Sensitive Receiver Types	Monitoring Location Mapping DDG Site shown as (red diamond)
23000	Human	

APPENDIX B DUST DEPOSITION GAUGE PROCEDURE

Dust Deposition Gauge Procedure

Revision 1: September 2021

1 Purpose

This Dust Deposition Gauge Procedure forms part of the Construction Air Quality Management Plan (CAQMP), a sub plan of the Construction Environment Management Plan (CEMP) for the construction of the Coffs Harbour Bypass.

Activities to be undertaken during construction have the potential to cause an increase in dust that can impact sensitive receivers within the vicinity of the Project. The purpose of this procedure is to outline the method for monitoring air quality adjacent to the Project alignment.

2 Scope

The procedure applies to locations adjacent to the Project alignment where dust fall out levels may be impacted by construction activities.

The procedure outlines the following:

- Site selection and positioning of dust deposition gauges
- Equipment
- Methodology
- Monitoring frequency, sample collection and analysis of dust samples
- Recording, analysis and reporting.

3 References

The following standards and factsheets have been used to write this Dust Deposition Gauge Procedure:

- AS/NZS 3580.1.1:2007: Methods for sampling and analysis of ambient air – Part 1.1: Guide to siting air monitoring equipment.
- AS/NZS 3580.10.1:2003: Methods for sampling and analysis of ambient air – Method 10.1: Determination of particulate matter —Deposited matter—Gravimetric method
- Environmental Defender's Office Ltd (NSW) Technical Fact Sheet: Air Quality – Dust Monitoring.

4 Procedure

4.1 Site selection and positioning dust deposition gauges

The dust deposition gauges (DDG's) will be positioned in accordance with the *AS/NZS 3580.1.1:2007: Methods for sampling and analysis of ambient air, Part 1.1: Guide to siting air monitoring equipment* will be followed. The following guidelines will be considered:

- DDG positions will be representative of the location. Dust gauge locations are provided in Appendix A of the Construction Air Quality Management Plan
- DDG will be positioned in low or sparsely built up areas
- Locations will be avoided where:
 - Airflow is restricted, such as behind trees or structures. DDG's should have a minimum clear sky angle of 120° (see Figure 4-1).
 - Objects might alter the pollution concentration by adsorption or absorption, such as leafy vegetation and some building materials

- Chemical interference may interfere with the pollutant being measures, such as near vehicle or plant emissions
- Physical interference may produce atypical results, such as domestic or commercial incinerators or where electrical interference to sampling equipment could occur from nearby high voltage power lines
- Where unrelated local emissions may interfere with the pollutant being measures.
- Monitoring site will be located where:
 - There is a low potential for vandalism
 - There is adequate access for transporting equipment
 - Staff can perform their activities in a safe environment.
- If DDG's are located on private property, permission must be granted by the land owner to access the gauges on a monthly basis.

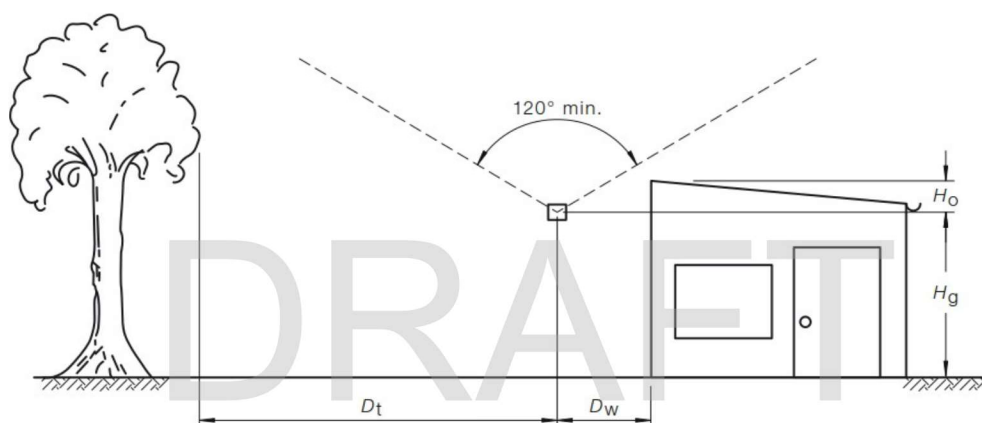

LEGEND:

- H_g = Height of sampling inlet above ground – 2 to 5 m for ground based sampling sites and up to 15 m for roof top sampling sites.
- H_o = Height of nearby obstacle above sampling inlet – $2H_o \leq D_w$
- D_t = Distance to nearby tree – ≥ 10 m
- D_w = Distance to wall (supporting structure) – minimum 1 m
- 120° = Minimum clear sky angle above sampling inlet

Figure 4-1 Generalised ground level sampling site (Source: A/NZS 3580.1.1:2007: Methods for sampling and analysis of ambient air – Part 1.1: Guide to siting air monitoring equipment)

4.2 Equipment

DDG's measure dust deposition rates by passive deposition and capture of dust using a funnel and bottle arrangement. The equipment required for DDG's includes:

- Grade A volumetric glassware, complying with AS2164 and its use complying with AS 2162.1.
- Pipettes complying with AS2166.
- Glass deposition gauges consisting of a 150 ± 10 mm diameter funnel (with a 60° angle of cone sides). The internal diameter of the funnel stem needs to be sufficient to permit passage of particulate matter during washing. It will be supported in the neck of a wide-mouth, glass bottle of a suitable size, preferably of minimum volume 4L, by means of a rubber or plastic stopper with a groove or outlet pipe to allow water overflow under excessive rainfall conditions.

- The funnel diameter shall be known to the nearest millimetre when used in calculating results (refer to Figure 4-2).
- Tight fitting, impermeable, non-reactive lid for deposition gauge collection and transportation.

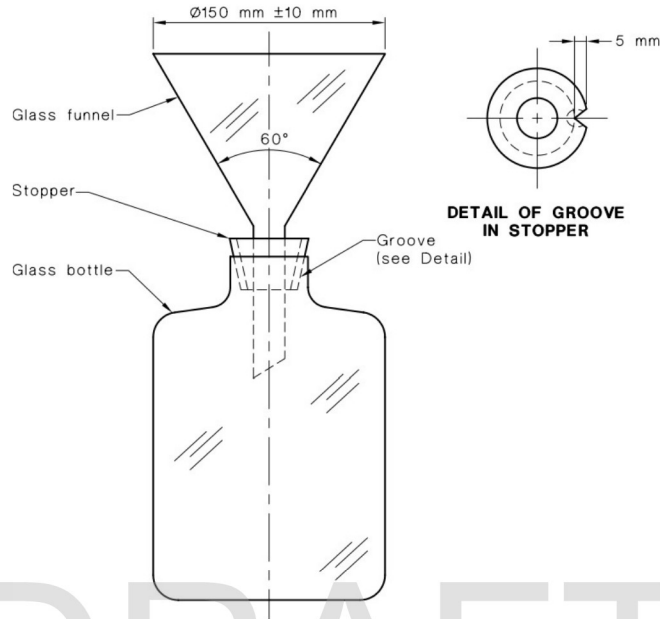

Figure 4-2 Typical standard deposition gauge (Source: A/NZS 3580.1.1:2007: Methods for sampling and analysis of ambient air – Part 1.1: Guide to siting air monitoring equipment)

- A stand supporting the horizontal plane of the funnel at a height of 2 ± 0.2 metres above the ground. The stand generally incorporates a container or beaker to protect the bottle contents from sunlight. A hole at the base should be provided to prevent rainwater build up (refer to figure 4-3).
- Filtration apparatus consisting of silica crucibles with porous filter bases (porosity 3) or Gooch crucible of porcelain, silica or alundum with filter pads of equivalent retention are acceptable for separation of the insoluble fraction from the soluble fraction. Alternatively, Buchner funnels with an appropriate filter pad of glass, quartz or ashless filter paper and membrane filters may be used.
- A bird ring made of inert or corrosion-resistant metal wire (diameter 4mm-6mm) with a suitable design to prevent birds perching on the funnel (optional).
- A test sieve with a 1mm aperture complying with AS 1152.

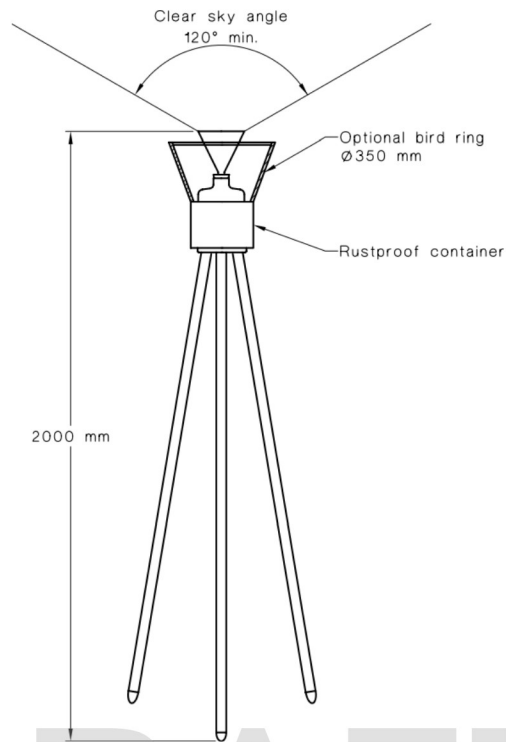

Figure 4-3 Typical stand with deposition gauge

4.3 Methodology

4.3.1 Preparation and installation

- Where permission is required to enter privately owned land for bottle change over, property owners will be contacted in accordance with the pre-arranged time frame.
- Once erected the stand will remain in-situ for the duration of the project or until there is sufficient proof that works being carried out are no longer affecting the monitoring site.
- All equipment will be labelled for traceability of each sample as it proceeds through the analysis process.
- The deposit gauge bottle will be prepared in accordance with AS/NZS 33580.10.1
- Each new bottle will be labelled with:
 - Location ID
 - Sample type (dust)
 - Date and time sampling commenced.

4.3.2 Gauge exchange procedure

- Ensure that the number on the bottle matched the number on the stand.
- At the end of the exposure period, wash any deposited matter adhering to the inside of the funnel into the deposit gauge bottle using a minimal volume of distilled water.
- Do not remove any collected rainwater, bugs, leaf litter, bird faeces or any other material from the glass bottle.
- Remove the funnel and attached stopper and seal the bottle with the specified lid.

- Fill in the dust deposition gauge sampling field sheet, noting any contamination to assist in identifying anomalies.
- Label the bottle with:
 - Location ID
 - Date sampling commenced and ended
 - Funnel diameter (to the nearest mm)
 - Recent activities in the area which may contribute to recorded dust fall out.
- Return bottles to the laboratory and perform analysis.
- Insert the clean funnel with attached stopper into a fresh bottle containing algicide and leave exposed for the next sampling period. Ensure that the funnel is firmly held in the neck of the bottle and that the funnel aperture is horizontal.
- Label the new bottle as described in Section 4.3.1.

4.3.3 Monitoring frequency, sample collection and analysis of dust samples

- Samples must be collected every 30 (± 2) days. AS/NZS 3580.10.1 recommends that gauges are changed on/ near to the first day of each month.
- A photo of the condition of each dust gauge shall be taken prior to the removal of each sample.
- The weather and any visible land use conditions adverse to local air quality shall be noted on a suitable field sheet and included in the relevant monthly monitoring report.
- When samples are collected, new laboratory prepared bottles will be taken to replace the old bottles to continue sampling for the next 30 days.
- Analysis of the sample should be performed as early as possible and within 30 days of collection. During storage, deposition gauges shall be tightly sealed and kept in a cool, dark environment to prevent the growth of algae, fungi or other micro-organisms.
- The following information must be supplied to the laboratory:
 - Location of DDG's including relevant information such as coordinates to within 100m, height above sea level, classification of area (e.g. industrial, residential, agricultural or urban)
 - Height above ground level at the given location
 - Date sampling commenced and ended
 - Recent activities in the area which may contribute to recorded dust fall out (e.g. meteorological conditions, proximity to bushfires, farm ploughing activities, traffic on unsealed roads).
- The following will be determined from analysis carried out by laboratory staff in accordance with procedures outlined in AS/NZS 3580.10.1:
 - Total solids
 - Insoluble solids
 - Ash and combustible matter
 - Soluble solids.

4.3.4 Recording, analysis and reporting

- Label each new bottle with:
 - Location ID
 - Sample type (dust)

- Date and time sampling commenced
- Complete all fields in the dust deposition gauge monitoring sheet (Appendix C in the CAQMP).
- Take a photograph of the glass bottle to keep on record with the dust deposition gauge monitoring sheet.
- Fill in the Chain of Custody sheet (provided by the laboratory), keep a photocopy on file and send original with samples to the laboratory.
- The test report will be submitted to Pacific Complete monthly outlining the requirements in AS/NZS 3580.10.1. Exceedances will be investigated by the Contractor Environment Manager to determine the validity of the results and adjust management practices if required.

DRAFT

APPENDIX C DUST DEPOSITION GAUGE FIELD SAMPLING SHEET

Gauge ID	Bottle installation		Collection		Total number of days	Funnel diameter (mm)	Collected by (name)	Comments – adjacent activities(harvesting), weather conditions, bushfires, contamination, signs of overflow	Date sent to lab
	Date	Time	Date	Time					

*This is a sample only

APPENDIX D DUST MONITORING LOCATIONS AND SENSITIVE RECEIVERS



Legend			
Construction footprint	Sensitive receivers	Residential	Outdoor recreation
North Coast Railway	Childcare	School	Active
Watercourse	Place of worship	Ecological receivers	Passive
Assessment boundary	Dust Depositional Gauge		
	Particulate Monitor (PM ₁₀ , PM _{2.5})		

Coffs Harbour Bypass
Air Quality Sensitive Receivers

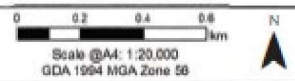

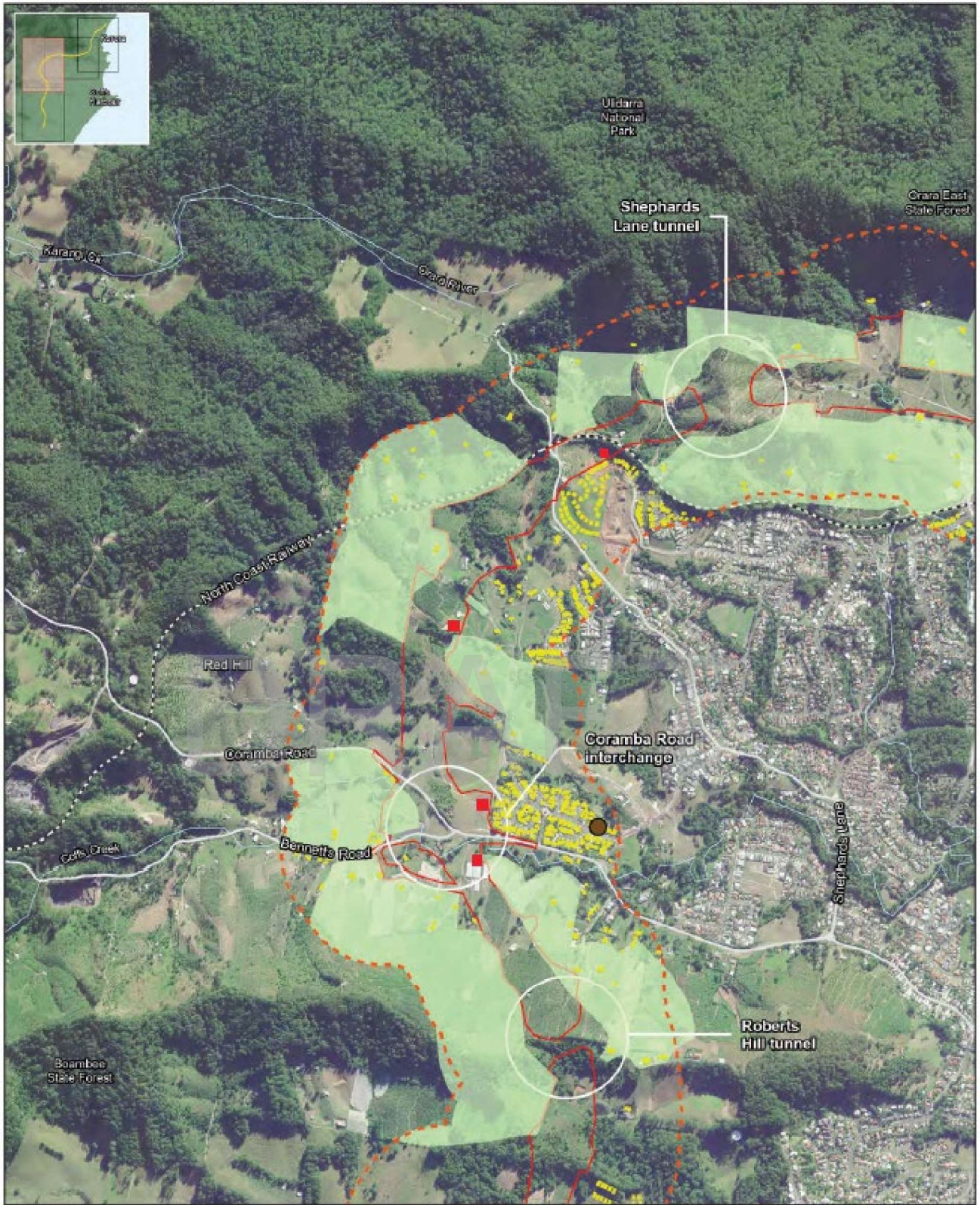

Legend			
Construction footprint	Sensitive receivers	Residential	Outdoor recreation
North Coast Railway	Childcare	School	Active
Watercourse	Place of worship	Ecological receivers	Passive
Assessment boundary	Dust Depositional Gauge		
	Particulate Monitor (PM ₁₀ , PM _{2.5})		

Coffs Harbour Bypass
Air Quality Sensitive Receivers

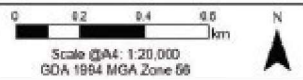

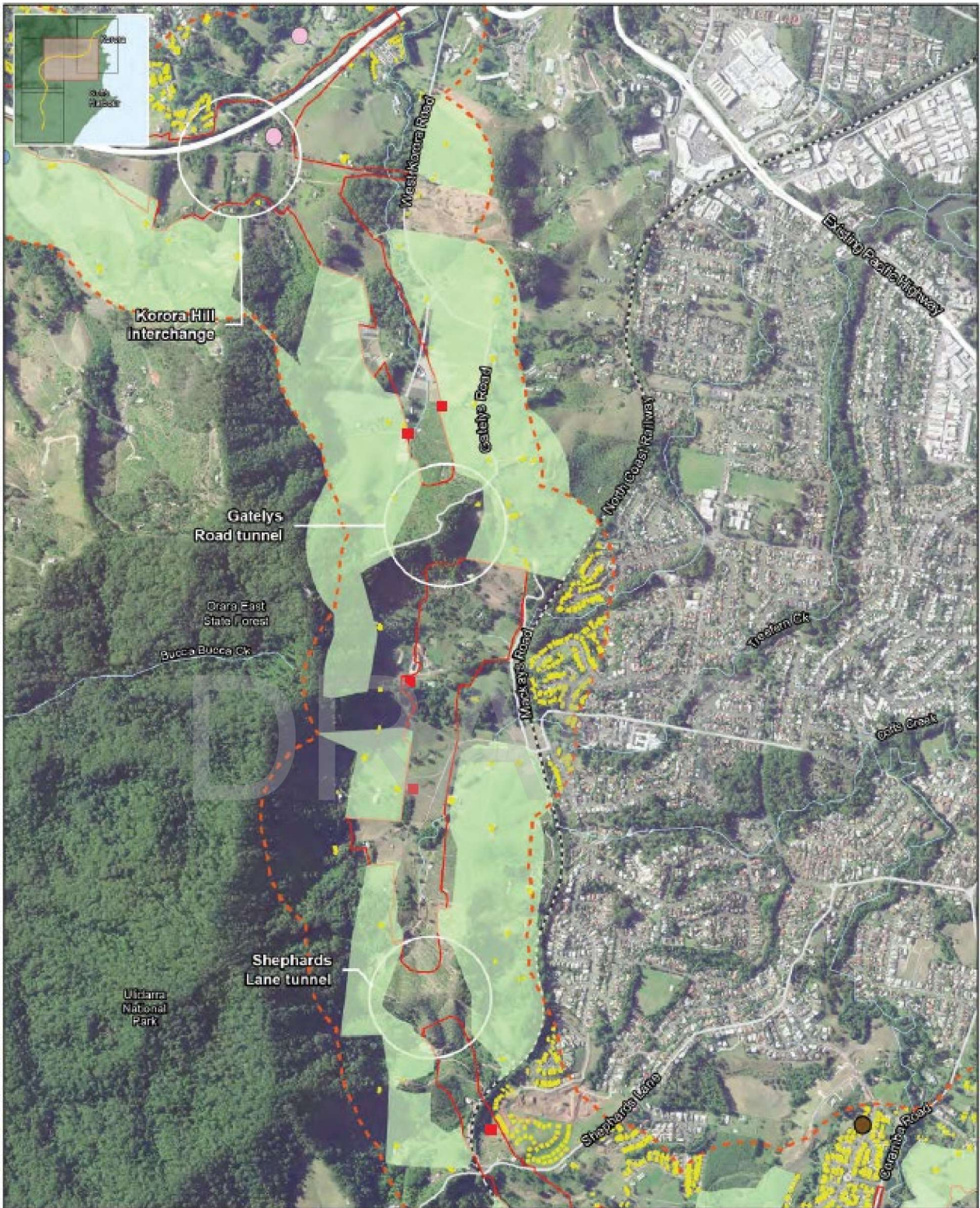

Legend

- | | | | |
|------------------------|---|----------------------|---------|
| Construction footprint | Childcare | Residential | Active |
| North Coast Railway | Place of worship | School | Passive |
| Watercourse | Dust Depositional Gauge | Ecological receivers | |
| Assessment boundary | Particulate Monitor (PM ₁₀ , PM _{2.5}) | | |

Coffs Harbour Bypass
Air Quality Sensitive Receivers

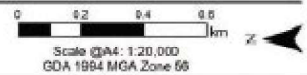



Legend

- | | | | |
|------------------------|---|----------------------|---------------------------|
| Construction footprint | Sensitive receivers | Residential | Outdoor recreation |
| North Coast Railway | Childcare | School | Active |
| Watercourse | Place of worship | Ecological receivers | Passive |
| Assessment boundary | Dust Depositional Gauge | | |
| | Particulate Monitor (PM ₁₀ , PM _{2.5}) | | |

Coffs Harbour Bypass
Air Quality Sensitive Receivers

